

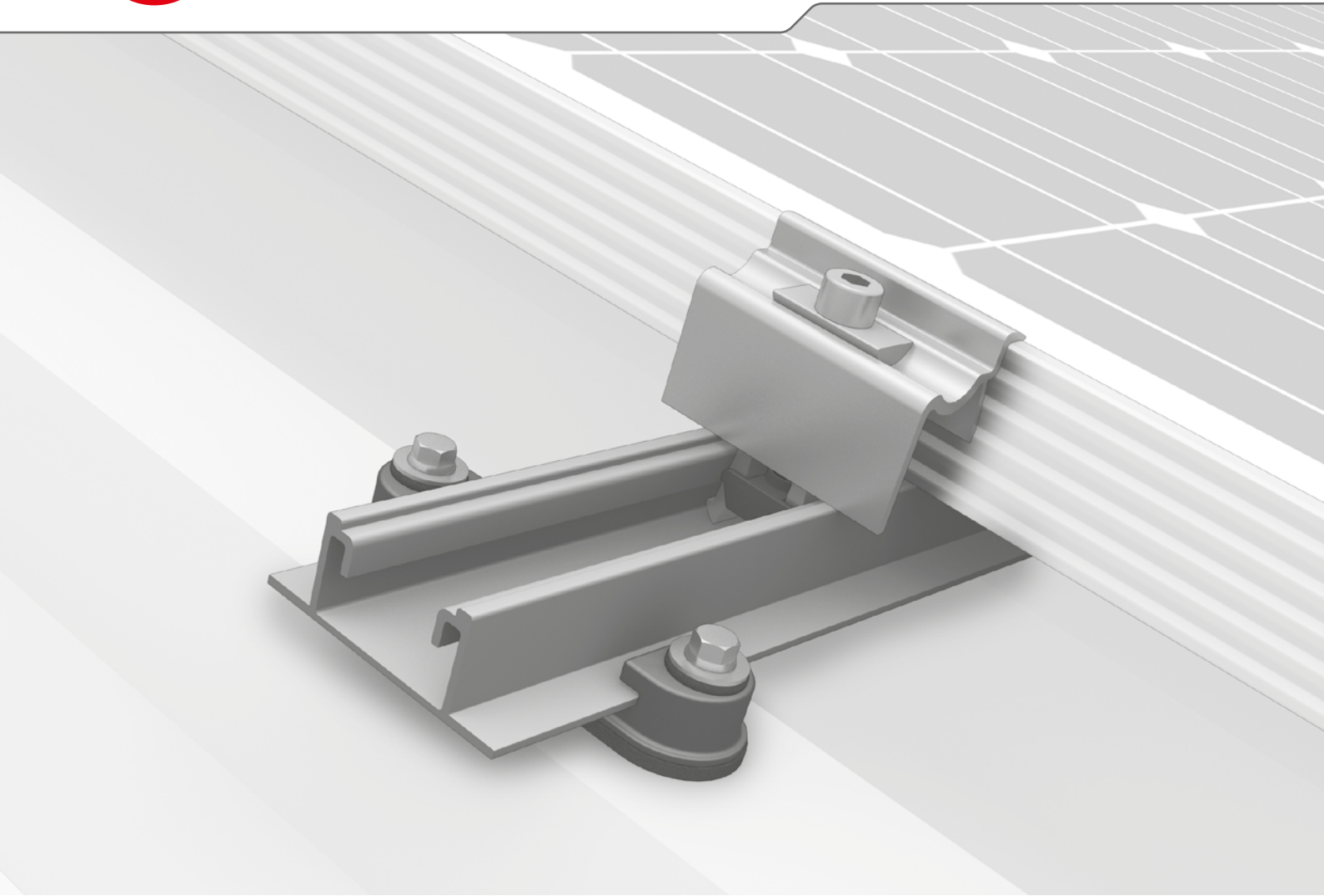

SpeedRail System



- ▶ The proven long rail system for trapezoidal sheet applications as well as floating suspension with controlled thermal linear expansion
- ▶ Our most popular system – over 1 GW installed worldwide
- ▶ All-rounder with only 4 installation steps – also suitable for high loads



Components

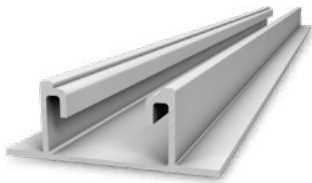

SpeedRail

- ▶ Mounting rail with easy insertion mounting into SpeedClips
- ▶ Various lengths available



SpeedClip

- ▶ Mounting brackets for SpeedRail
- ▶ Simple insertion feature
- ▶ Glass fibre reinforced polyamide with EPDM seals
- ▶ Fastened with self-drilling screws for trapezoidal sheet metal

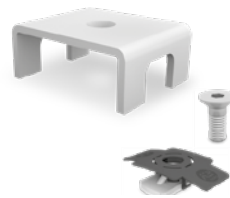

SpeedLock

- ▶ Mounting lock for SpeedRail in case of thermal expansion
- ▶ In a set with MK2 slot nut and stainless steel screw



SpeedConnector

- ▶ Rail connector for SpeedRail
- ▶ Three boreholes for flexible mounting
- ▶ In a set with countersunk screws

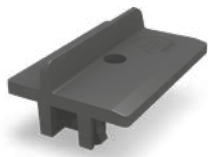

AddOn

- ▶ For grid mounting and ensures easy shared-rail mounting
- ▶ Glass fibre reinforced polyamide

Technical data

SpeedRail / SpeedClip	
Scope of application	Trapezoidal sheet roof
Fastening type / roof fixture	Insertion mounting into SpeedClips and screws in the roofing
Requirements	<ul style="list-style-type: none"> ▶ Sheet thickness: ≥ 0.4 mm steel and ≥ 0.5 mm aluminium ▶ Sandwich panel: Approval from manufacturer required ▶ Crest width: At least 22 mm ▶ Flush area surrounding the bore hole: $\varnothing \geq 20$ mm
Material	<ul style="list-style-type: none"> ▶ SpeedRail: Aluminium (EN AW-6063 T66; 0.64 kg/m) ▶ SpeedClip: Glass fibre reinforced polyamide with EPDM
SpeedRail dimensions W = width [mm] H = height [mm] L = lengths [m]	63 22.5 1.15/2.10/3.25/4.30/5.40
SpeedClip dimensions	See drawing
Second rail layer	SingleRail or SolidRail

