

DE TECHNISCHE INFORMATION / MONTAGEANLEITUNG

Duschwanne

EN TECHNICAL INFORMATION / INSTALLATION INSTRUCTIONS

Shower tray

FR INFORMATIONS TECHNIQUE / INSTRUCTIONS DE MONTAGE

Bac de douche

NL TECHNISCHE INFORMATIE / MONTAGEHANDLEIDING

Douchebak WTW



Sicherheitshinweise, Safety Notes, Consignes de sécurité, Veiligheidsvoorschriften

- DE** ● Die am Montageort geltenden Vorschriften und Normen sind zu beachten.
- Die Installation ist von einer Fachfirma auszuführen. Nichtbeachtung führt zum Verlust der Garantieleistungen.
- EN** ● The standards and regulations applicable at the installation location must be adhered to.
- The installation must be carried out by authorized professionals. Non-compliance renders the warranty void
- FR** ● Respectez les normes et réglementations du pays où est réalisée l'installation
- Le montage doivent être effectués par une entreprise qualifiée et agréée. Le non-respect de ces règles entraîne la perte des prestations de garantie.
- De ter plaatse geldende normen en voorschriften moeten toegepast worden.
- Installatie moet door een bekwaam Installatiebedrijf aan de hand van de geldige handleidingen uitgevoerd worden. Montage die niet in overeenstemming met onze voorschriften wordt uitgevoerd, leidt tot verlies van garantie.

Technische Daten, Technical Data, Données techniques, Technische gegevens

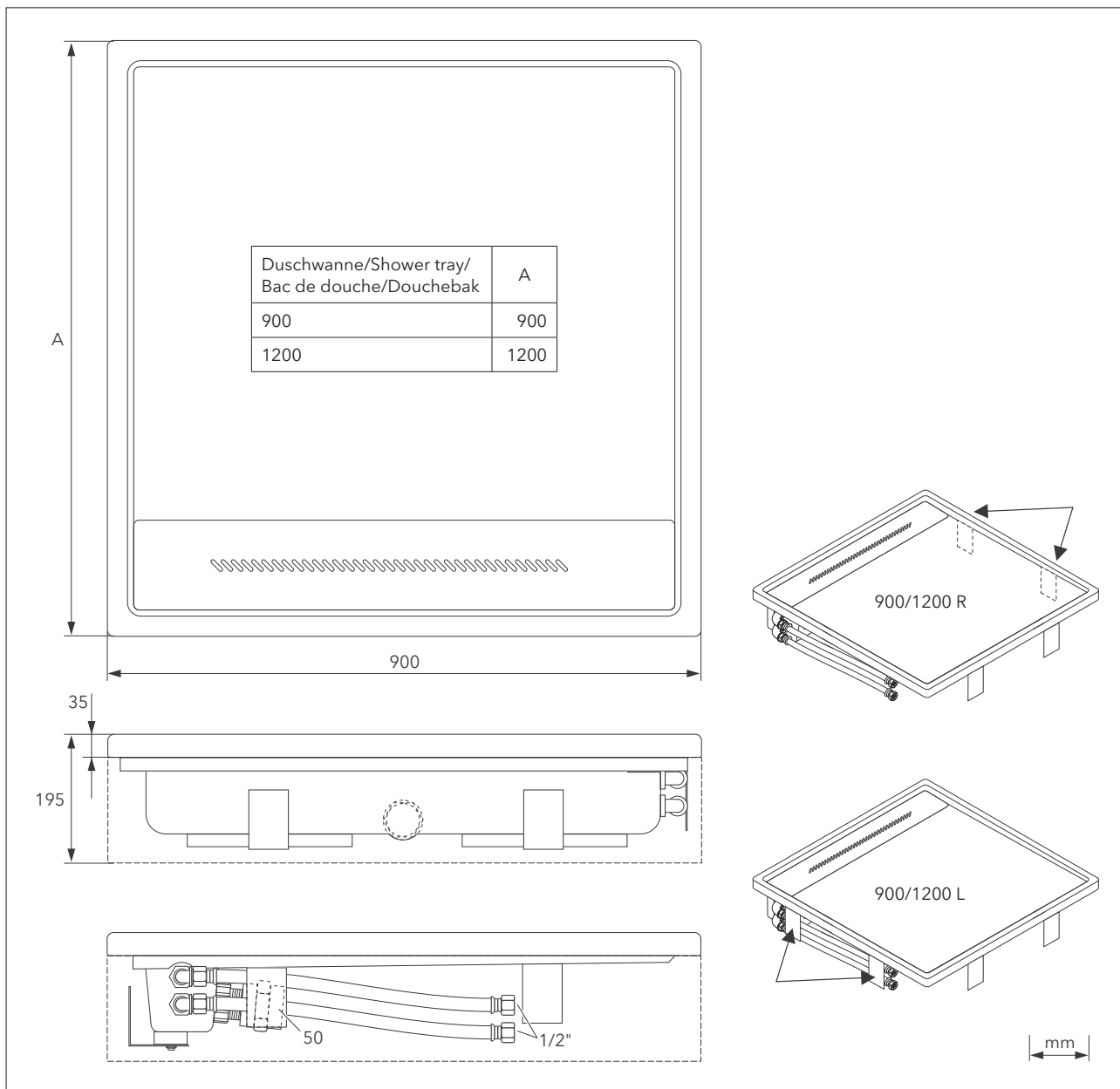

Duschwanne/Shower tray/Bac de douche/Douchebak 900 / 1200			
Durchflussmenge / Flow rate / Débit / Debiet (l/min)	5,8	9,2	12,5
Druckverlust / Pressure drop / Perte de charge / Drukverlies (bar)	0,18	0,39	0,52
Wirkungsgrad / Efficiency / Rendement / Rendementsfactor (%) (NEN 7120, Annex B)	50,6	50,6	48,3
Max. Betriebsdruck / Max. operating pressure / Pression de service max. / Max. bedrijfsdruk (bar)	10		
Anschluss Trinkwasser / Connection domestic water / Branchement d'eau potable / Drinkwaterzijdige aansluitingen	½" Überwurfmutter flachdichtend / female, flat sealing / Écrou à collet battu à joint plat / Wartelmoer, vlak dichtend		
Anschluss Abwasser / Waste water connection / Branchement d'évacuation / Afvoer	50 mm innen / inside / intérieur / inwendig		
Duschwanne / Shower tray / Bac de douche / Douchebak	Sanitäracryl / Sanitary acrylic / acrylique sanitaire / Acryl		
Rost / Grate / Griille / Rooster	Edelstahl / Stainless steel / Inox / RVS		
Wärmeübertrager / Heat exchanger / Convertisseur de chaleur / Warmtewisselaar	Kupfer, doppelwandig / Copper, double-walled / Cuivre double paroi / Koper, dubbelwandig		

Montage/Installation

DE Anschluss

Anschluss nach Bild A: optimale Wirkung
Anschluss nach Bild B/C: reduzierter Wirkungsgrad, gegebenenfalls Berechnung erforderlich.
Die Verwendung einer Thermostatarmatur für die Dusche wird nachdrücklich empfohlen.

EN Connecting

Connecting as Fig. A: best efficiency
Connecting as Fig. B/C: reduced efficiency, calculation may be required.
The use of a thermostatic shower mixer tap is strongly recommended.

Raccordement

Raccordement selon image A: rendement optimal
Raccordement selon image B/C: efficacité réduite, des calculs peuvent être nécessaires.
L'utilisation d'une armature de douche à thermostat est vivement recommandé.

Aansluiting

Aansluiten conform figuur A: maximale rendement
Aansluiten conform figuur B/C: beperkt rendement verlies, zie EPC software voor de uitwerking in uw woning.
Het gebruik van een thermostatische douchemengkraan wordt sterk aanbevolen.

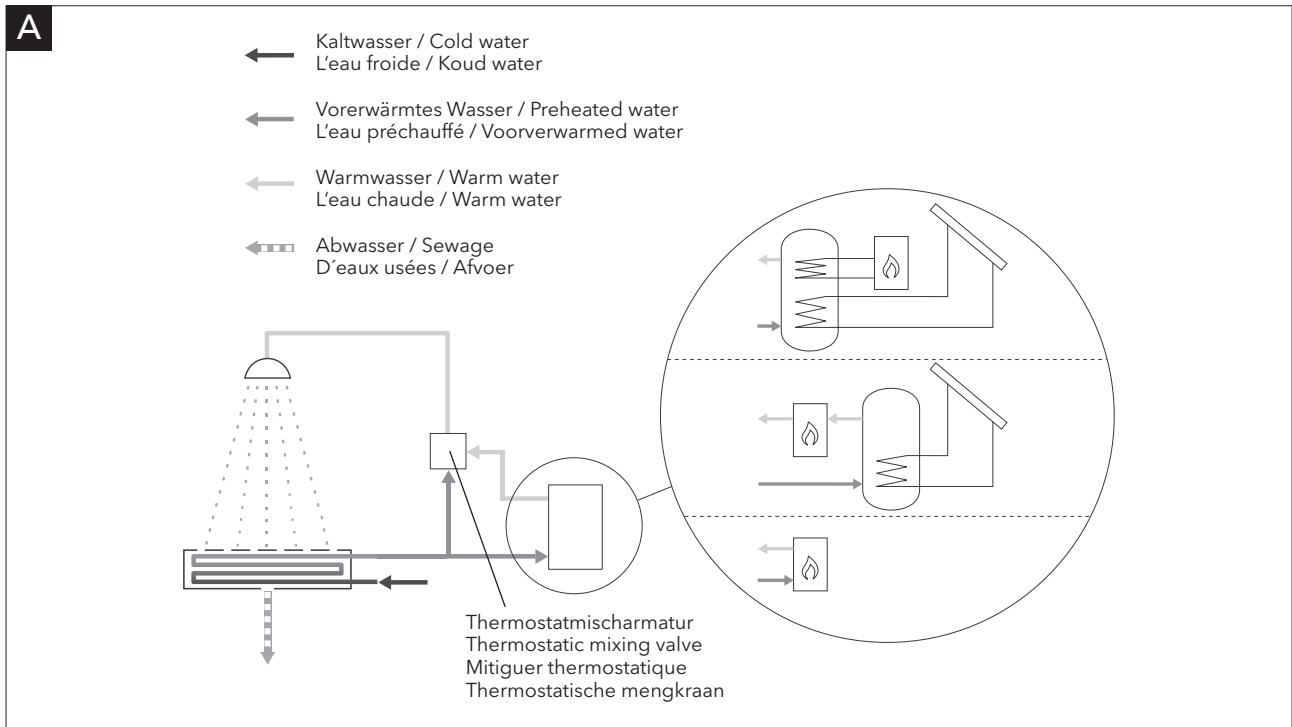

A Anschluss an Duscharmatur und Warmwasserbereitung / Connection to shower armature and Water heater / Raccordement à l'armature de douche et au chauffe-eau Aansluiting zowel op de koude zijde van de douchemengkraan als ook op de warmwater bereider

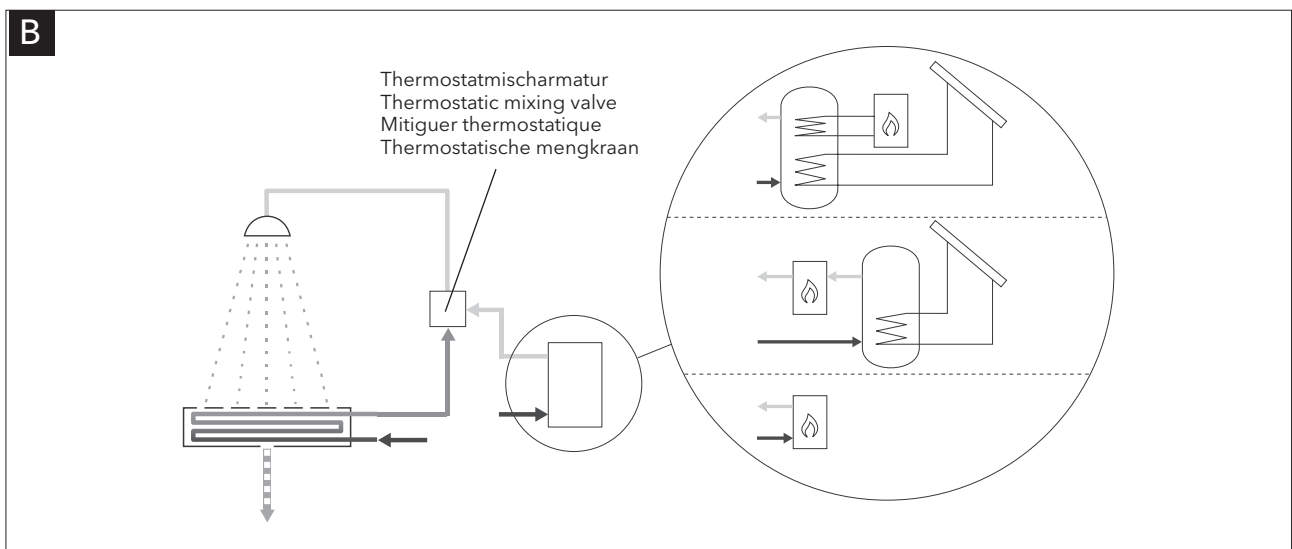

B Anschluss an Duscharmatur / Connection to shower armature/ Raccordement à l'armature de douche / Aansluiting op de koude zijde van de douchemengkraan

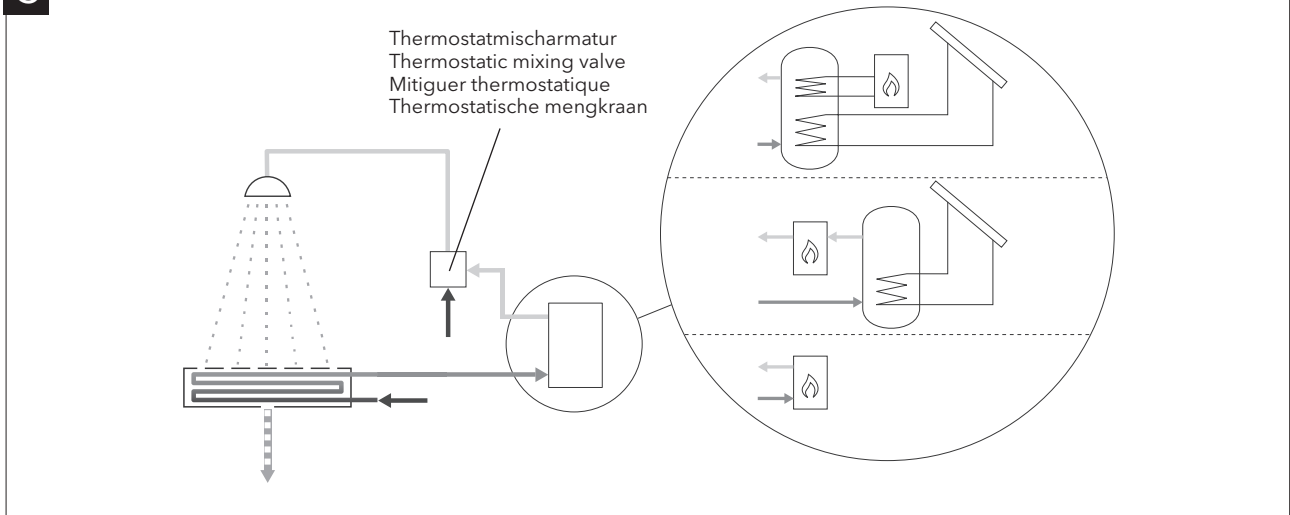
C

C Anschluss an Warmwasserbereitung / Connection to water heater / Raccord au chauffe-eau / Aansluiting op de warmwater bereider

Lieferumfang/Scope of supply/Contenu de la livraison/Leveringsomvang

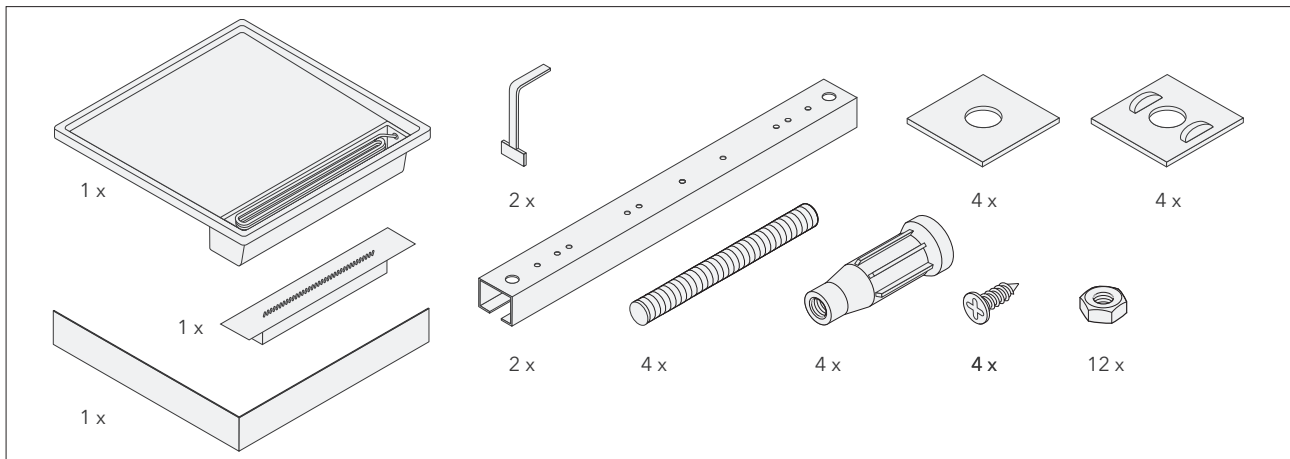

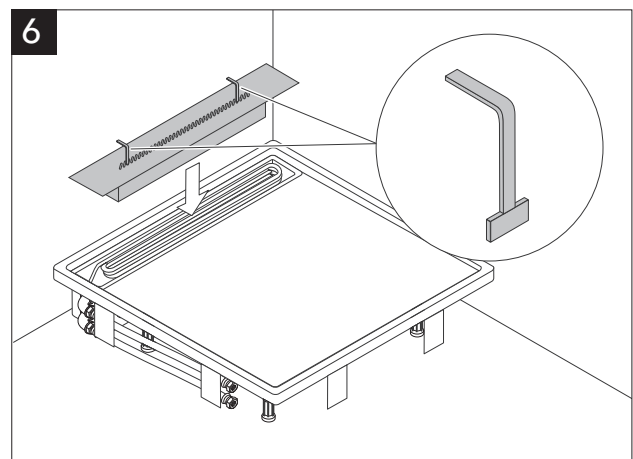
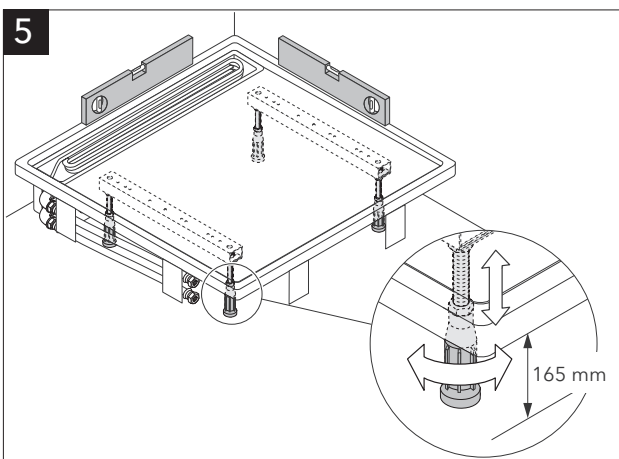
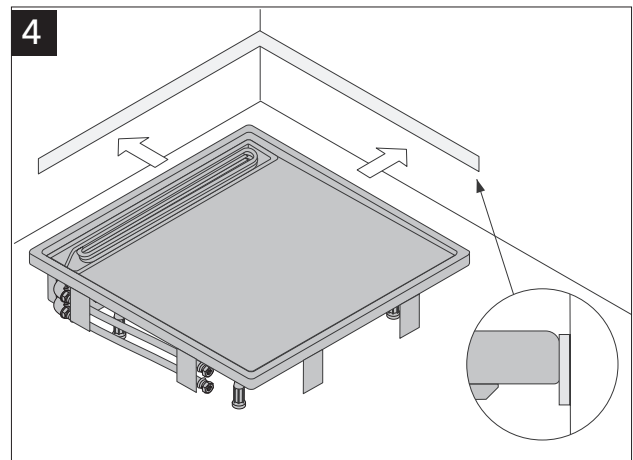
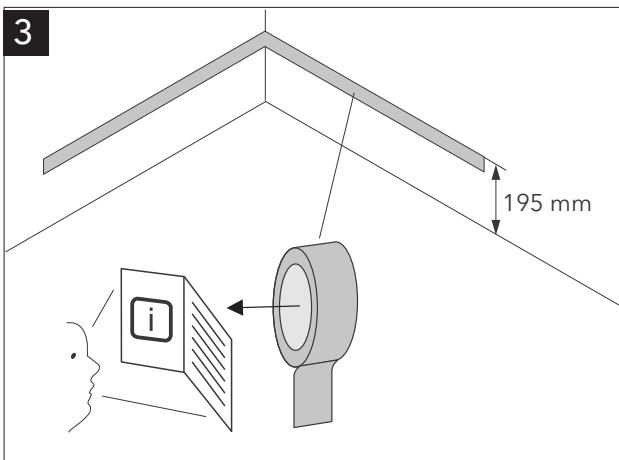
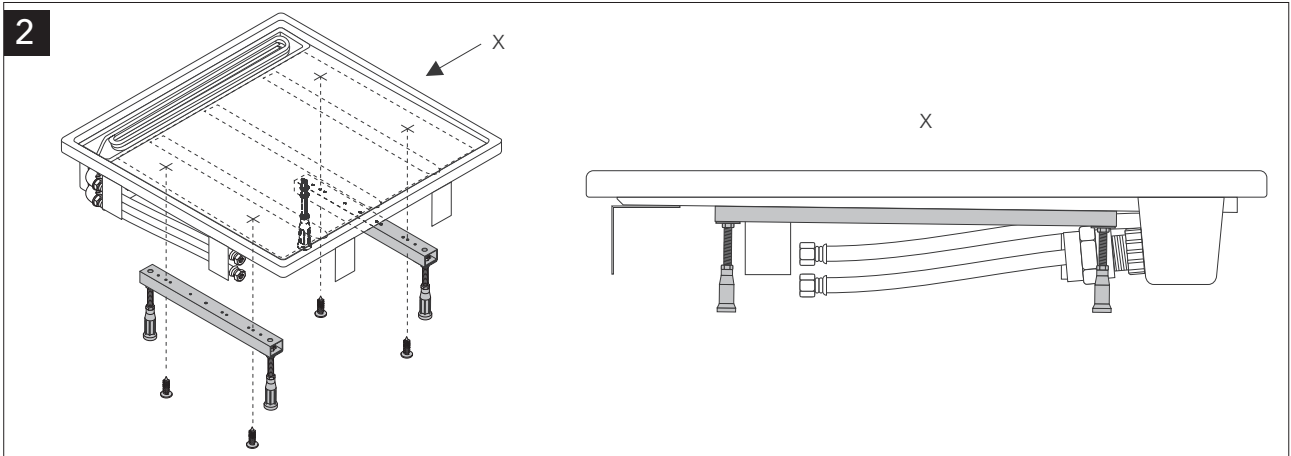
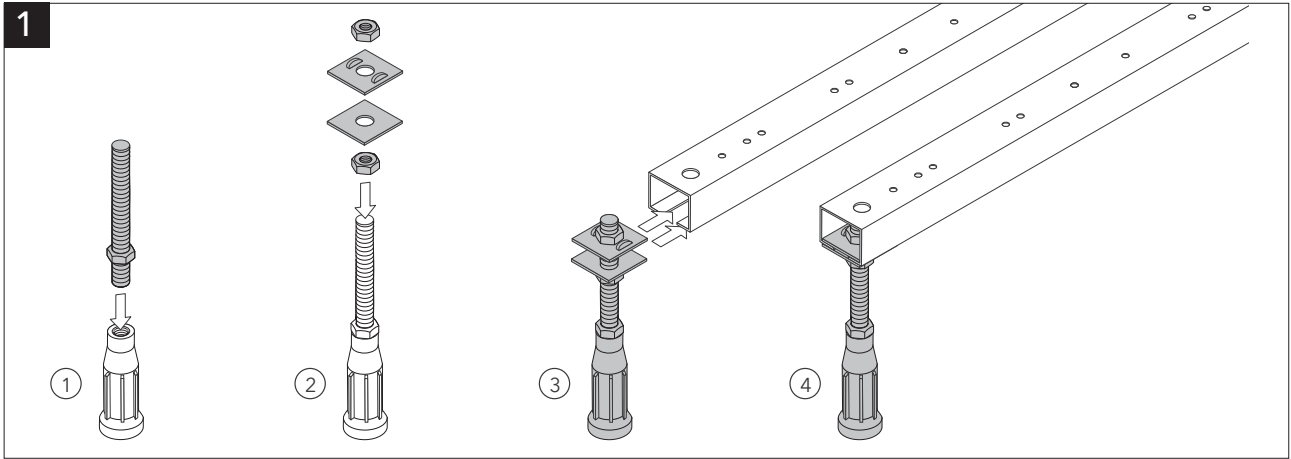

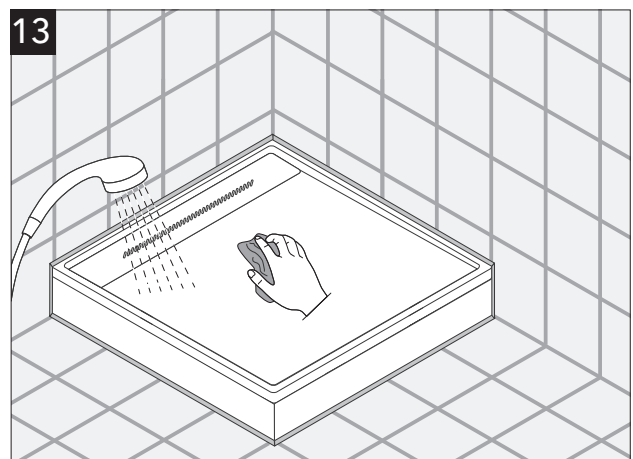
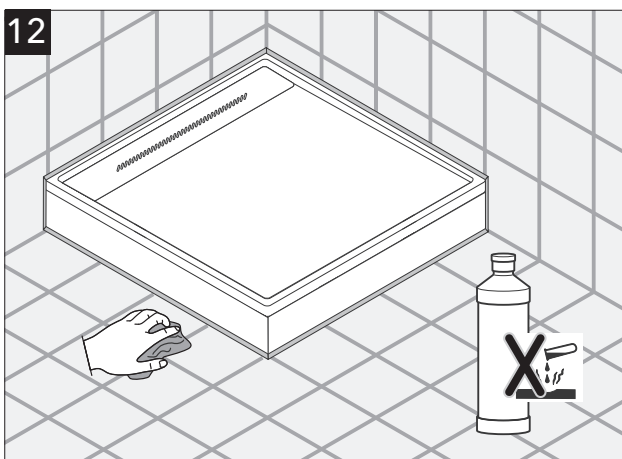
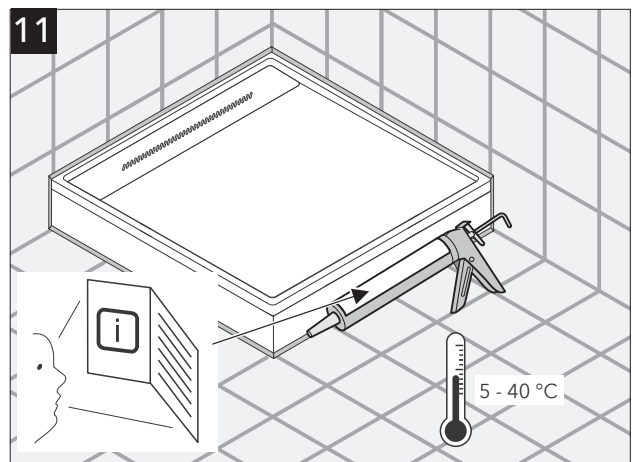
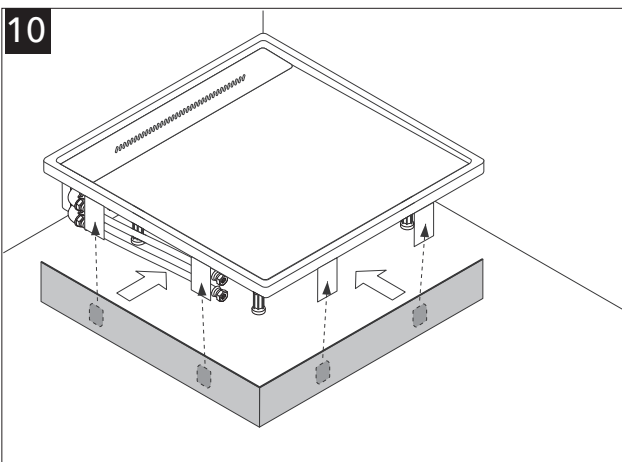
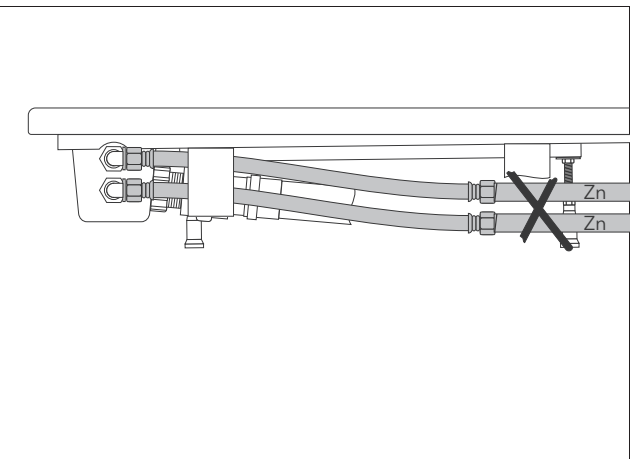
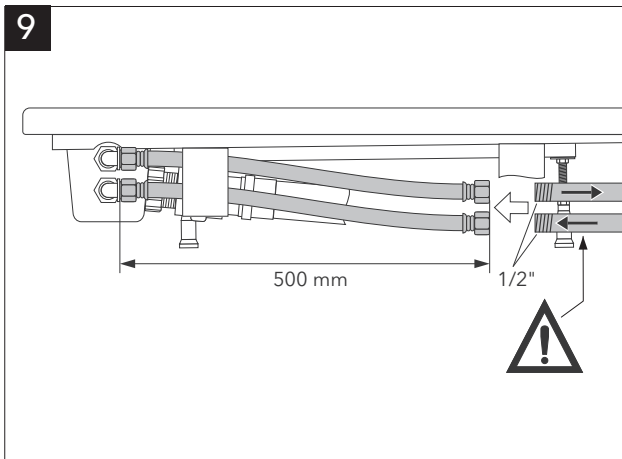
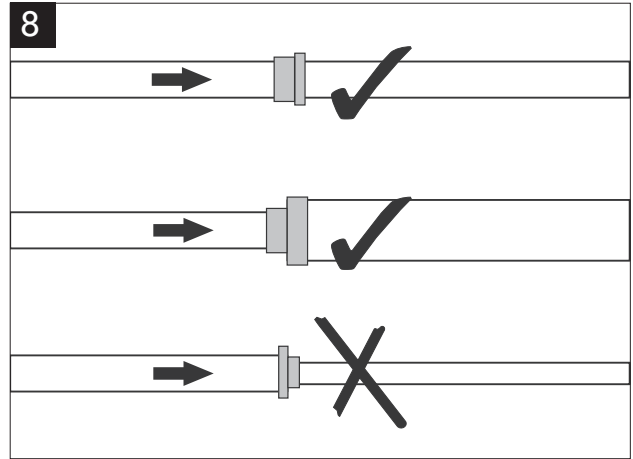
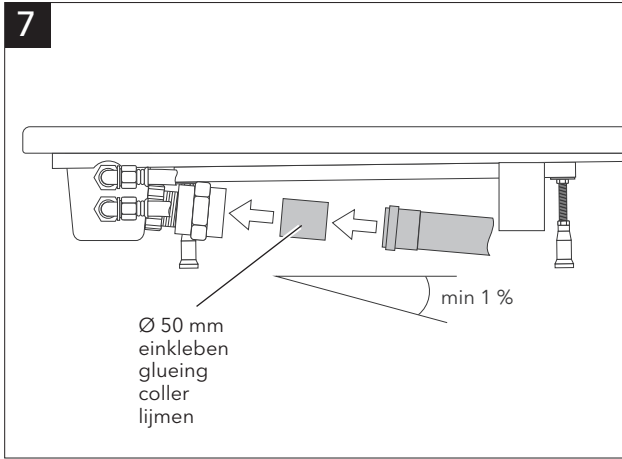

Wartung/Maintenance/Onderhoud

