

tubra[®] - eTherm P3+

Montage- und Bedienungsanleitung

Inhalt

1	Einführung	3
1.1	Verwendungszweck	3
1.2	Sicherheitshinweise	3
1.3	Mitgeltende Unterlagen	5
1.4	Lieferung und Transport	5
2	Funktionsbeschreibung	6
2.1	Systemaufbau in der Installation	6
2.2	Funktionsbeschreibung	6
3	Aufbau – Lieferumfang	7
4	Technische Daten	8
4.1	Allgemein	8
4.2	Abmessungen / Platzbedarf	8
4.3	Druckverlust / Pumpenkennlinie	9
4.4	Anschlüsse	9
5	Montage	10
5.1	Wandmontage	10
5.2	Hydraulischer Anschluss Pufferspeicher	10
5.3	Elektrischer Anschluss	11
5.4	Kaskadierung	13
6	Inbetriebnahme	14
6.1	Dichtheitsprüfung und Füllen der Anlage	14
6.2	Erstinbetriebnahme	15
7	Bedienung	15
7.1	Regelung	15
7.2	Schwerkraftbremse	15
7.3	Einstellungen	15
8	Wartung / Service	16
9	Störungen, Ursachen und Beseitigung	17
10	Außerbetriebnahme	18

1 Einführung

Diese Anleitung beschreibt die Montage der elektrothermischen Station **tubra®-eTherm P3+** sowie die Bedienung und die Wartung.

Die Anleitung richtet sich an ausgebildete Fachhandwerker, die entsprechende Kenntnisse im Umgang mit Heizungsanlagen, Wasserleitungsinstallationen und mit Elektroinstallationen haben. Die Installation und Inbetriebnahme darf nur durch ausgebildetes Fachpersonal vorgenommen werden.

Die Station darf nur in frostgeschützten, trockenen Räumlichkeiten montiert und betrieben werden. Lesen Sie diese Anleitung vor Beginn der Montagearbeiten sorgfältig durch. Bei Nichtbeachtung entfallen sämtliche Garantie- und Gewährleistungsansprüche.

Abbildungen sind symbolisch und können vom jeweiligen Produkt abweichen. Technische Änderungen und Irrtümer vorbehalten.

Diese Montage- und Bedienungsanleitung darf ohne schriftliche Genehmigung weder vervielfältigt noch Dritten zugänglich gemacht werden (§ 2 UrhG, § 823 BGB).

1.1 Verwendungszweck

Die elektrothermische Station **tubra®-eTherm P3+** dient ausschließlich zur Erwärmung von Wasser mittels Elektroheizelement im Durchflussprinzip. Es darf nur Heizungswasser (HW) nach VDI 2035 erwärmt werden.

1.2 Sicherheitshinweise

Neben länderspezifischen Richtlinien und örtlichen Vorschriften sind folgende Regeln der Technik zu beachten:

- DIN 1988 Technische Regeln für die Trinkwasserinstallation
- DIN 18 380 Heizanlagen und zentrale Wassererwärmungsanlagen
- VDI 2035 Steinbildung in Trinkwassererwärmungsanlagen und Warmwasserheizungsanlagen
- DIN 4753 Wassererwärmer und Wassererwärmungsanlagen für Trink- und Betriebswasser
- DIN EN 60335-1 Sicherheit elektrischer Geräte für den Hausgebrauch und ähnliche Zwecke Teil 1: Allgemeine Anforderungen
- DIN EN 60335-2 Sicherheit elektrischer Geräte für den Hausgebrauch und ähnliche Zwecke Teil 2: Besondere Anforderungen
- TrinkwV Trinkwasserverordnung
- DVGW W551 Trinkwassererwärmungs- und Trinkwasserleitungsanlagen
- BGV Berufsgenossenschaftliche Vorschrift (Unfallverhütungsvorschriften)
- VDE 0100 Normenreihe Errichtung elektrischer Anlagen
- EN 806-2 Technische Regeln für Trinkwasserinstallationen – Anforderungen an Bauteile, Apparate und Werkstoffe
- Bestimmungen der örtlichen Energie- und Wasserversorgungsunternehmen
- Angaben auf Typenschild
- Technische Daten



Da Temperaturen an der Anlage > 60 °C entstehen können, besteht Verbrühungsgefahr und eventuell Verbrennungsgefahr an den Komponenten.

Zielgruppe

Diese Bedienungsanleitung richtet sich an die Benutzer der Heizungsanlage. Dieses Gerät kann von Kindern ab 3 Jahren und darüber und von Personen mit eingeschränkten körperlichen, sensorischen oder geistigen Fähigkeiten oder Personen mit mangelnder Erfahrung und mangelnden Kenntnissen benutzt werden, wenn sie beaufsichtigt oder bezüglich des sicheren Gebrauchs des Geräts unterwiesen wurden und die daraus resultierenden Gefahren verstanden haben.

 Achtung	Kinder in der Nähe des Geräts beaufsichtigen. <ul style="list-style-type: none"> - Kinder dürfen nicht mit dem Gerät spielen. - Reinigung und Benutzerwartung dürfen nicht von Kindern ohne Beaufsichtigung durchgeführt werden.
-----------------------------------------------------------------------------------------------------	----------------------------------------------------------------------------------------------------------------------------------------------------------------------------------------------------------------------------------------------------------

Anschluss des Geräts

Diese Bedienungsanleitung richtet sich an die Benutzer der Heizungsanlage.

- Das Gerät darf nur von autorisierten Fachkräften angeschlossen und in Betrieb genommen werden.
- Die vorgegebenen elektrischen Anschlussbedingungen einhalten.
- Änderungen an der bestehenden Installation dürfen nur von autorisierten Fachkräften durchgeführt werden.

 Gefahr	Unsachgemäß durchgeführte Arbeiten an der Heizungsanlage können zu lebensbedrohenden Unfällen führen. <ul style="list-style-type: none"> - Elektroarbeiten dürfen nur von Elektrofachkräften durchgeführt werden.
----------------------------------------------------------------------------------------------------	----------------------------------------------------------------------------------------------------------------------------------------------------------------------------------------------------------------------------------

Arbeiten am Gerät

- Einstellungen und Arbeiten am Gerät nur nach den Vorgaben in dieser Bedienungsanleitung ausführen. Weitere Arbeiten am Gerät dürfen nur von autorisierten Fachkräften ausgeführt werden.
- Gerät nicht öffnen.
- Das Gehäuse nicht abnehmen.
- Installiertes Zubehör oder Anbauteile nicht verändern oder entfernen.
- Rohrverbindungen nicht öffnen oder nachziehen.

 Gefahr	Heiße Oberflächen und Flüssigkeiten können zu Verbrennungen oder Verbrühungen führen. <ul style="list-style-type: none"> - Gerät nicht öffnen. - Heiße Oberflächen an ungedämmten Rohren und Armaturen nicht berühren.
------------------------------------------------------------------------------------------------------	------------------------------------------------------------------------------------------------------------------------------------------------------------------------------------------------------------------------------------------------

Beschädigungen am Gerät

 Gefahr	Beschädigte Geräte gefährden Ihre Sicherheit. <ul style="list-style-type: none"> - Gerät auf äußere Schäden prüfen. - Ein beschädigtes Gerät nicht in Betrieb nehmen.
------------------------------------------------------------------------------------------------------	-----------------------------------------------------------------------------------------------------------------------------------------------------------------------------------------------

Wasseraustritt aus dem Gerät

 Gefahr	Bei Wasseraustritt aus dem Gerät besteht die Gefahr eines Stromschlags. <ul style="list-style-type: none"> - Die Heizungsanlage an der externen Trennvorrichtung (z. B. Sicherungskasten, Hausstromverteilung) ausschalten. - Heizungsfachbetrieb benachrichtigen.
------------------------------------------------------------------------------------------------------	--------------------------------------------------------------------------------------------------------------------------------------------------------------------------------------------------------------------------------------------------------------------------------------------

 Gefahr	Wenn Wasser aus dem Gerät austritt, besteht Verbrühungsgefahr. <ul style="list-style-type: none"> - Heißes Heizwasser nicht berühren.
------------------------------------------------------------------------------------------------------	------------------------------------------------------------------------------------------------------------------------------------------------------

Verhalten bei Störungen an der Heizungsanlage

 Gefahr	Störungsmeldungen weisen auf Defekte an der Heizungsanlage hin. Nicht behobene Störungen können lebensbedrohliche Folgen haben. <ul style="list-style-type: none"> - Störungsmeldungen nicht mehrmals in kurzen Abständen quittieren. - Fachbetrieb benachrichtigen, damit dieser die Ursache analysieren und den Defekt beheben kann.
---------------------------------------------------------------------------------------------	----------------------------------------------------------------------------------------------------------------------------------------------------------------------------------------------------------------------------------------------------------------------------------------------------------------------------------------------------------------

Anforderungen an den Aufstellort

 Gefahr	Keine nachträglichen Änderungen der baulichen Gegebenheiten vornehmen, die Auswirkungen auf den sicheren Betrieb haben können (z. B. Leitungsverlegung, Verkleidungen oder Trennwände).
---------------------------------------------------------------------------------------------	-----------------------------------------------------------------------------------------------------------------------------------------------------------------------------------------

 Gefahr	Leicht entflammbare Flüssigkeiten und Materialien (z. B. Benzin, Lösungs- und Reinigungsmittel, Farben oder Papier) können Verpuffungen und Brände auslösen. Solche Stoffe nicht im Heizraum und nicht in unmittelbarer Nähe der Heizungsanlage lagern oder verwenden.
---------------------------------------------------------------------------------------------	------------------------------------------------------------------------------------------------------------------------------------------------------------------------------------------------------------------------------------------------------------------------

 Achtung	Unzulässige Umgebungsbedingungen können Schäden an der Heizungsanlage verursachen und einen sicheren Betrieb gefährden. <ul style="list-style-type: none"> - Umgebungstemperatur zwischen 0 °C und 35 °C gewährleisten. - Luftverunreinigungen durch Halogenkohlenwasserstoffe (z. B. enthalten in Farben, Lösungs- und Reinigungsmitteln) und starken Staubanfall (z. B. durch Schleifarbeiten) vermeiden. - Dauerhaft hohe Luftfeuchtigkeit (z. B. durch permanente Wäschetrocknung) vermeiden.
----------------------------------------------------------------------------------------------	------------------------------------------------------------------------------------------------------------------------------------------------------------------------------------------------------------------------------------------------------------------------------------------------------------------------------------------------------------------------------------------------------------------------------------------------------------------------------------------------------------------------------------

Zusatzkomponenten, Ersatz- und Verschleißteile

 Achtung	Komponenten, die nicht mit der Heizungsanlage geprüft wurden, können Schäden an der Heizungsanlage hervorrufen oder deren Funktionen beeinträchtigen. Anbau oder Austausch ausschließlich durch den Fachbetrieb ausführen lassen.
------------------------------------------------------------------------------------------------	-----------------------------------------------------------------------------------------------------------------------------------------------------------------------------------------------------------------------------------

1.3 Mitgeltende Unterlagen

Beachten Sie auch die Montage- und Bedienungsanleitungen der verwendeten Komponenten wie z.B. der Regelung.

1.4 Lieferung und Transport

Überprüfen Sie unmittelbar nach Erhalt der Lieferung die Ware auf Vollständigkeit und Unversehrtheit. Eventuelle Schäden oder Reklamationen sind umgehend zu melden.

2 Funktionsbeschreibung

2.1 Systemaufbau in der Installation

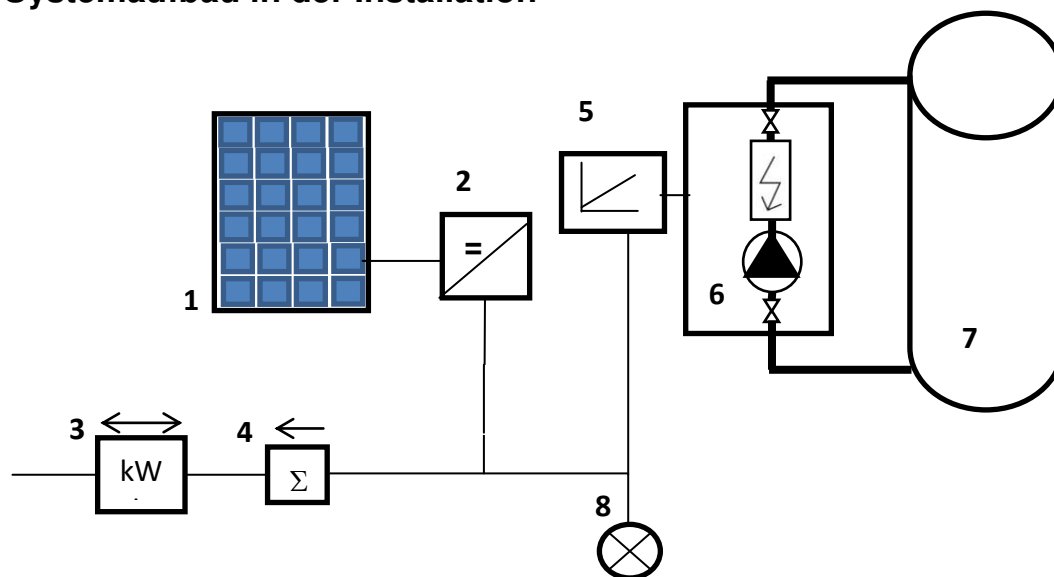

- 1 Photovoltaikanlage
- 2 Wechselrichter
- 3 Stromzähler (Bezug, Einspeisung)
- 4 tubra®-eTherm P3+ sensor (Leistungsmessung Einspeisung)
- 5 tubra®-eTherm P3+ power (Leistungsmodulation)
- 6 tubra®-eTherm P3+ mit tubra®-eTherm controller P
- 7 Thermischer Speicher
- 8 Haushaltsverbraucher (Licht, Standby, ...)

2.2 Funktionsbeschreibung

Die **tubra®-eTherm P3+** ist eine elektrothermische Station zur Umwandlung von Photovoltaikstrom in Wärme und zur Speicherung dieser Wärme in Pufferspeichern. Mit der stufenlosen Leistungsregelung der **tubra®-eTherm P3+** können Stromüberschüsse optimal verwertet werden. Über die drehzahlgeregelte Ladepumpe wird der Speicher mit einem sofort nutzbaren Temperaturniveau beladen. Wenn die Speichermaximaltemperatur erreicht ist, wird die Beladung beendet.

Vorteile sind:

- Optimale Anpassung durch stufenlos modulierende Leistung bis 3000 W
- Geschichtete Speicherbeladung auch bei der Nachrüstung an vorhandenen Speicher
- Zieltemperatur einstellbar
- Sofort nutzbare Wärme auch bei geringer Solarstrahlung
- Nachrüstbar an jedem Pufferspeicher
- Unabhängig vom PV-Wechselrichter, Energiemanager und Stromzähler

Die Regelungseinheit besteht aus dem Regler (6), dem Leistungsteil (6) und dem Messteil (4). Das mitgelieferte Messteil misst den Stromfluss unmittelbar vor dem Stromzähler (3). Wenn eine ausreichend hohe Leistung detektiert wird, kann dieser Photovoltaikstrom zur elektrischen Warmwasserbereitung verwendet werden. Der Regler regelt über das Leistungsteil die Leistungsstufen in der elektrothermischen Station zur Beheizung des Speichers. Dank Durchlauferhitzer-Prinzip mit Drehzahlregelung der Pumpe liefert die **tubra®-eTherm P3+** bereits bei geringer Heizleistung, z.B. an bedeckten Tagen, Wärme auf einem hohen Temperaturniveau in den Speicher. Damit kann der Pufferspeicher schichtend beladen werden.

3 Aufbau – Lieferumfang

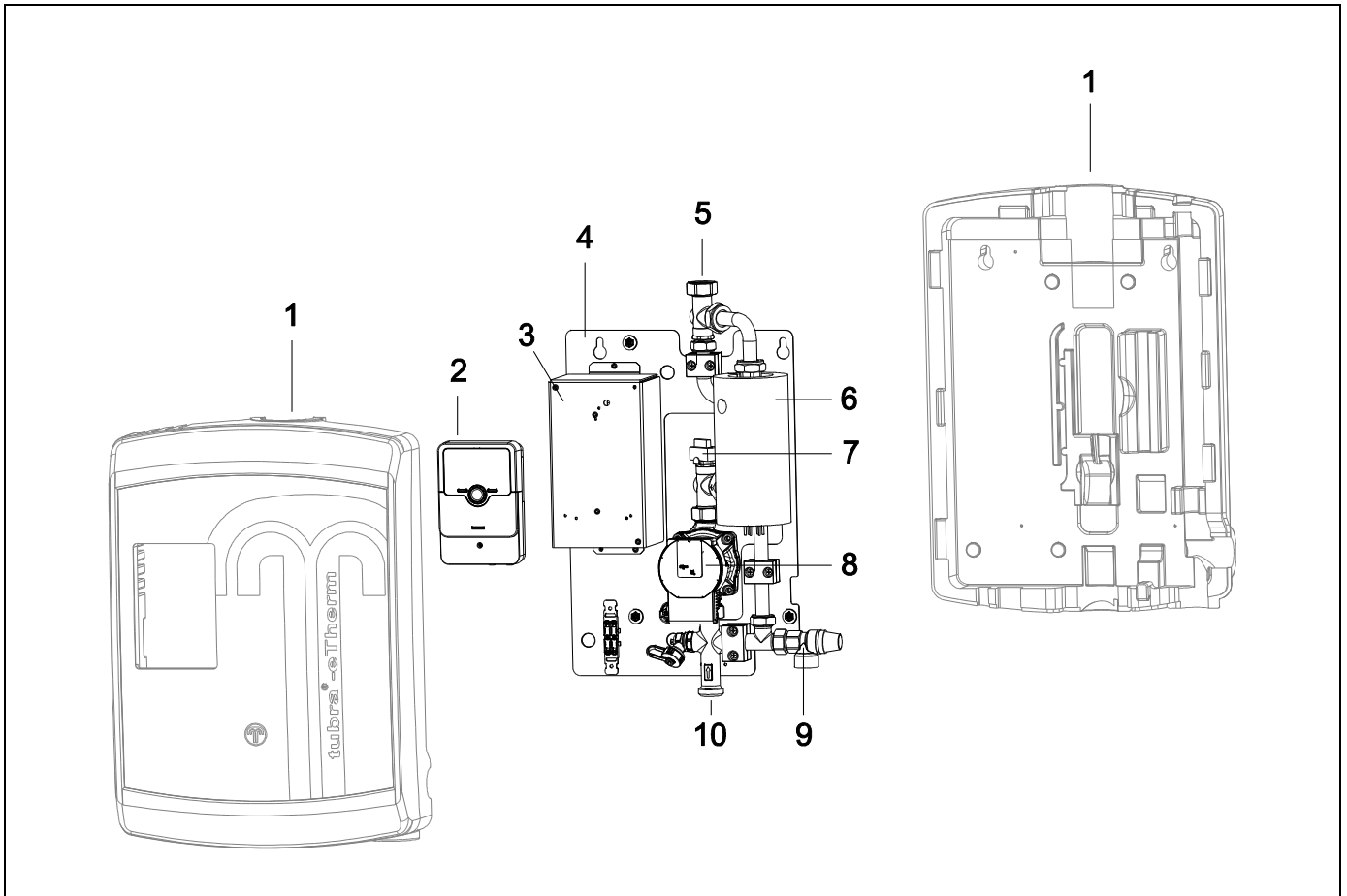

Pos.	Bezeichnung
1	Dämmschale
2	Regelung
3	Anschlussbox für STB und Schaltschütze
4	Grundplatte
5	Vorlauf Kugelhahn
6	Elektroheizelement + Dämmschale
7	Drucksensor
8	Pumpe
9	Kreuzstück mit Sicherheitsventil 3bar
10	Rücklauf Kugelhahn

4 Technische Daten

4.1 Allgemein

Bezeichnung / Typ	tubra®-eTherm P3+
Nennleistung / -strom	0 – 3 kW (13 A)
Elektroanschluss	1/PE 230 V AC 50 – 60 Hz
Erforderl. Leitungsquerschnitt	2,5 mm ²
Nenninhalt	0,2 l
Heizelement	0,8 kW / 0,8 kW / 1,4 kW
Durchfluss	2 l/h – 300 l/h
Druckverlust	0,6 bar bei 300 l/h
Temperatureinstellbereich	30 °C – 80 °C
Wasseranschluss	Rp 3/4" IG
Gewicht (mit Wasserfüllung)	14 kg
Schutzart eTherm power	IP 22

Bezeichnung / Typ	tubra®-eTherm P3+ 951.15.00.00
Ausführung	Heizungswasser
Nennleistung	0 - 3 kW
Max. Betriebsdruck	3 bar
Max. Betriebstemperatur	95 °C
Umwälzpumpe	Wilo Para ST 15/7 iPWM2 Leistungsaufnahme: 3-45 W

Werkstoffe	Gehäuse/ Anschlusssteile	CW617N (2.0402)
	Heizelement	Cu-Ausführung
	Dichtungen	EPDM
	Dämmung	EPP- Schaum 0,038 W/mK

4.2 Abmessungen / Platzbedarf

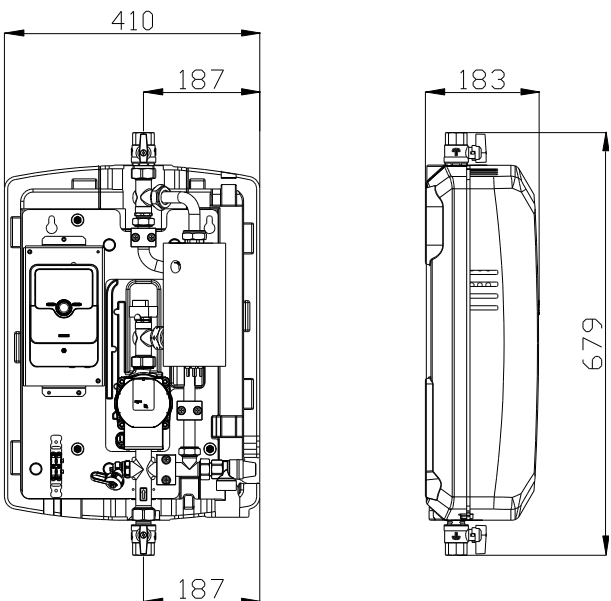
	Abmessungen und Mindestplatzbedarf für Montage- und Wartungsarbeiten
-------------------------------------------------------------------------------------	----------------------------------------------------------------------

4.3 Druckverlust / Pumpenkennlinie

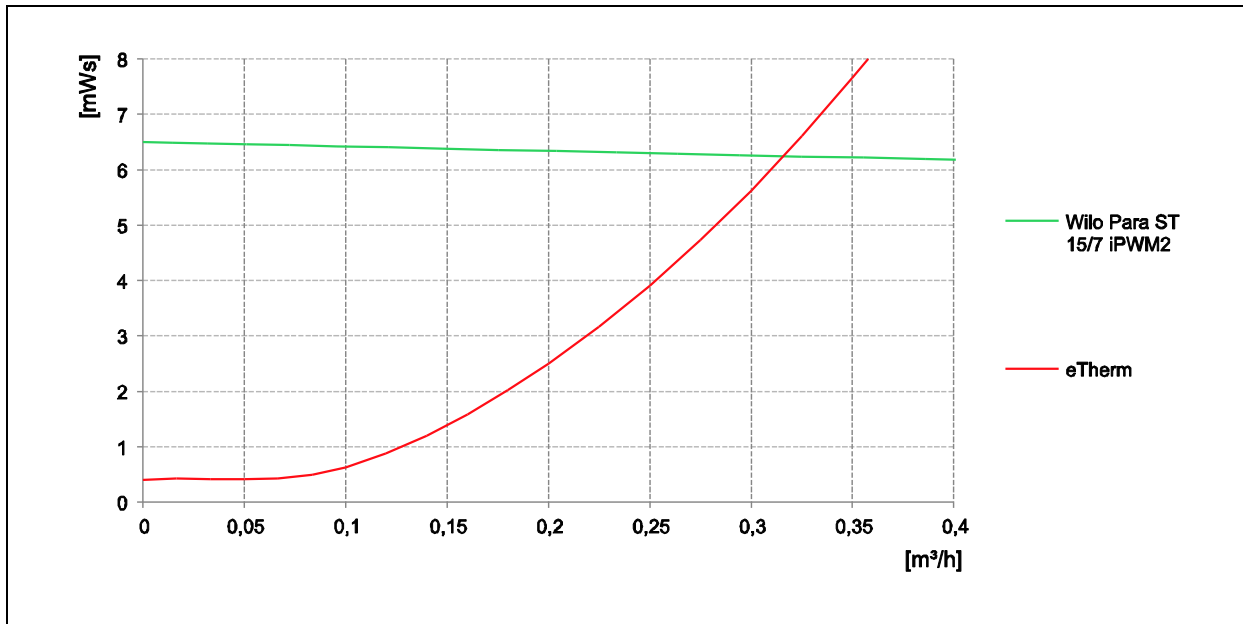

4.4 Anschlüsse

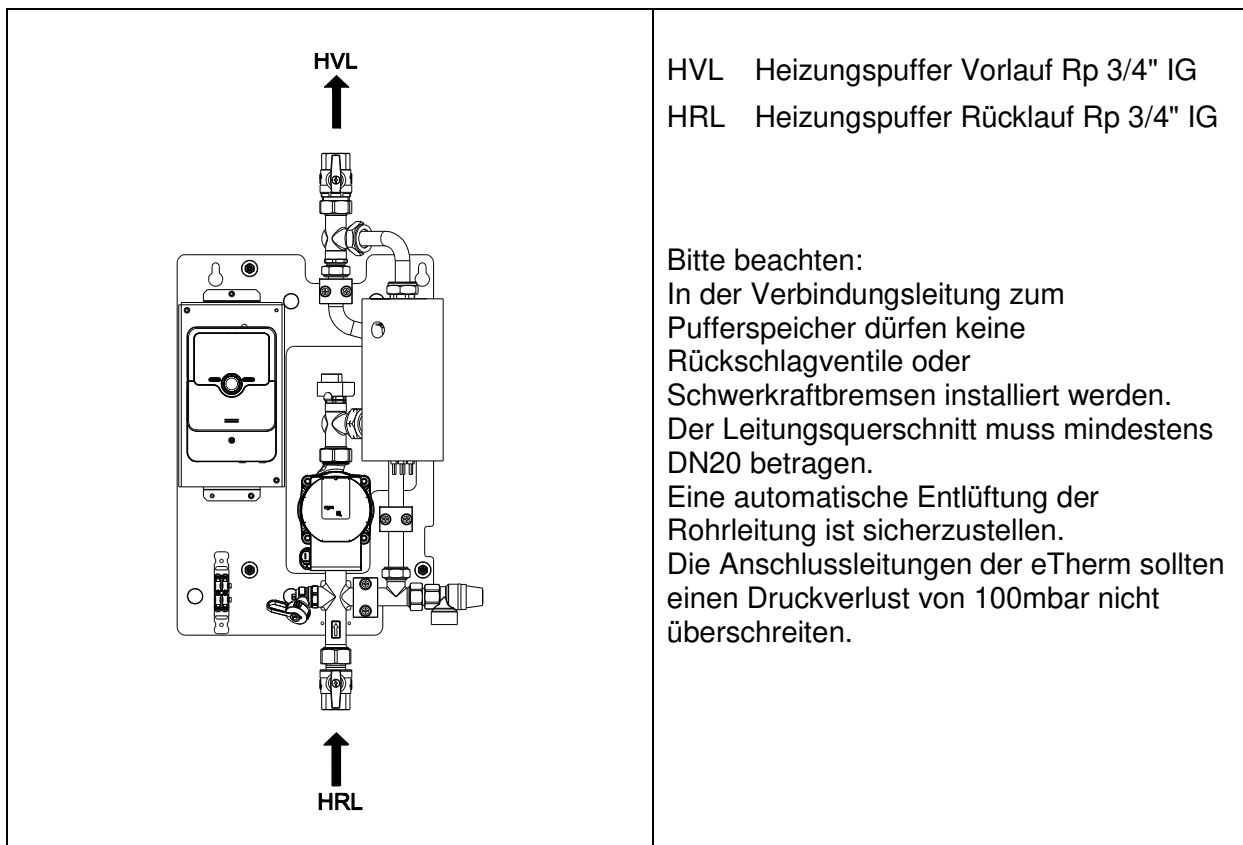

5 Montage

5.1 Wandmontage

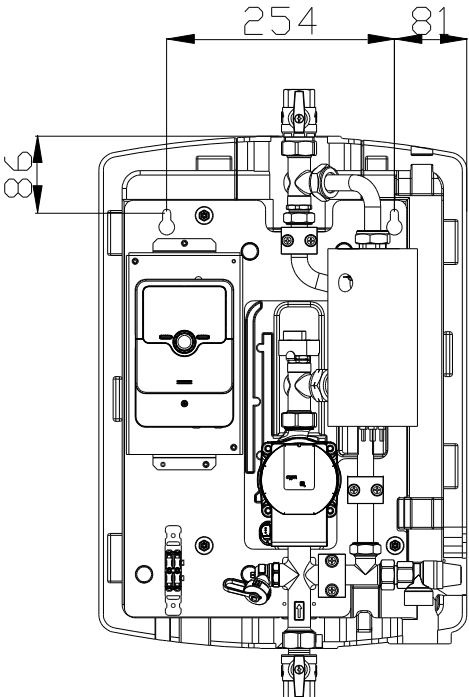
	<p>Zwei Löcher \varnothing 10mm entsprechend nebenstehender Abbildung anzeichnen, bohren und Spreizdübel setzen. Die obere Schraube mit Unterlegscheibe eindrehen, bis Schraubenkopf ca. 1 cm Abstand zur Wand hat. Station einhängen, mit Wasserwaage ausrichten und mit zweiter Schraube und Unterlegscheibe fixieren.</p> <p>Beide Schrauben gleichmäßig festschrauben.</p>
-----------------------------------------------------------------------------------	-----------------------------------------------------------------------------------------------------------------------------------------------------------------------------------------------------------------------------------------------------------------------------------------------------------------------------------------------------------------------------------------------------

5.2 Hydraulischer Anschluss Pufferspeicher

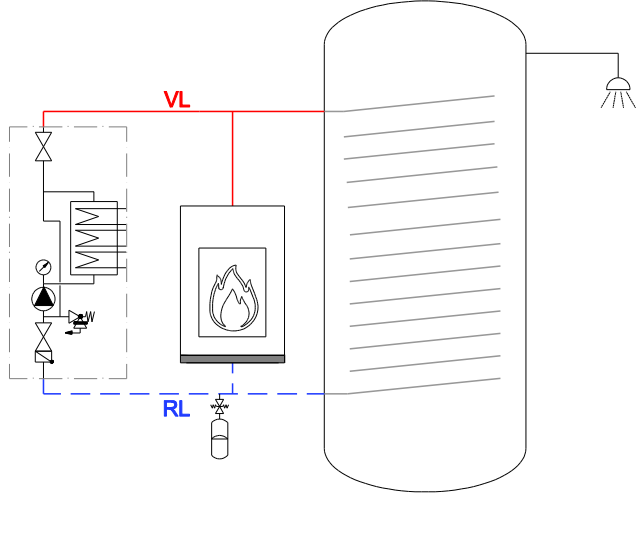
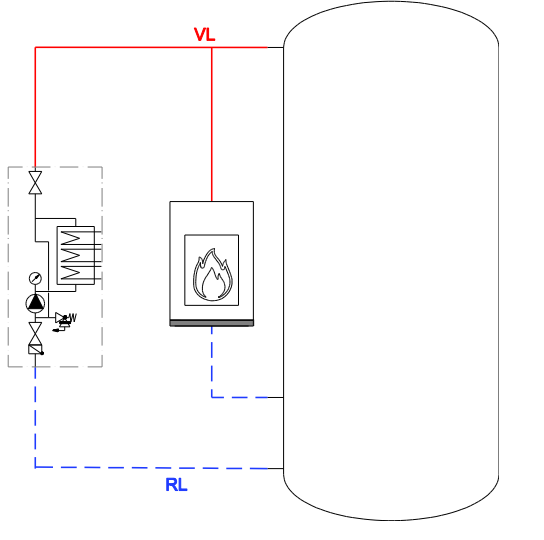
tubra [®] -eTherm P3+ mit Trinkwasserspeicher	tubra [®] -eTherm P3+ mit Pufferspeicher
	
Beispieldarstellung, erhebt keinen Anspruch auf Vollständigkeit und ersetzt keine fachmännische Planung.	
Bezeichnung	Beschreibung
VL	Vorlauf
RL	Rücklauf

5.3 Elektrischer Anschluss

5.3.1 Allgemein

Arbeiten an der elektrischen Anlage sowie das Öffnen von Elektrogehäusen darf nur in spannungsfreiem Zustand und nur von autorisiertem Fachpersonal durchgeführt werden. Bei den Anschlüssen auf richtige Klemmenbelegung und Polarität achten. Die Regelung und die elektrischen Bauteile vor Überspannung schützen.

 Gefahr!	<p>Bei unsachgemäßem elektrischen Anschluss besteht Lebensgefahr durch Stromschlag.</p> <ul style="list-style-type: none"> → Elektrischen Anschluss nur durch vom örtlichen Energieversorger zugelassenen Elektroinstallateur und entsprechend den örtlich geltenden Vorschriften ausführen lassen. → Vor dem Arbeiten die Versorgungsspannung trennen.
-----------------------------------------------------------------------------------------------------	---------------------------------------------------------------------------------------------------------------------------------------------------------------------------------------------------------------------------------------------------------------------------------------------------------------------------------------------------------------------------------

Die Station ist werksseitig komplett vormontiert und vorverdrahtet. Zur Inbetriebnahme das Netzkabel anschließen und die Bus-Verbindung zur Regeleinheit herstellen.

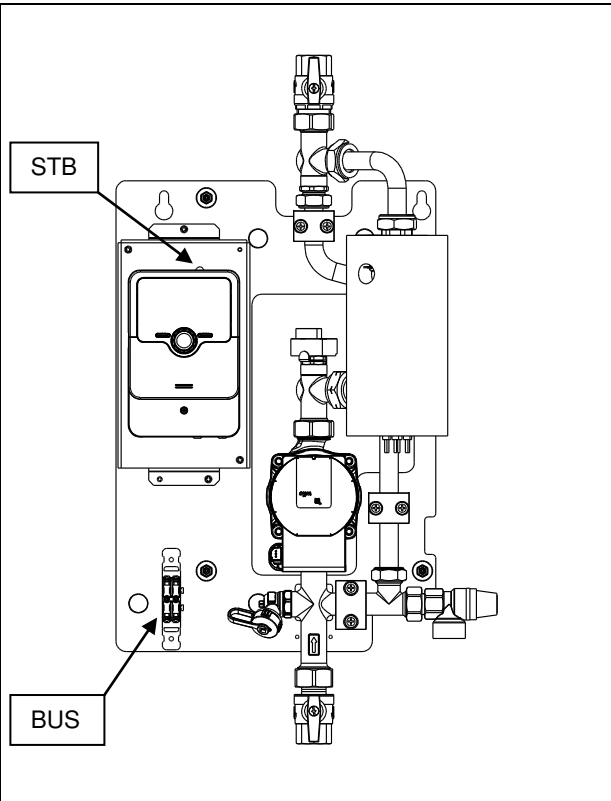
	<p>Der Netzanschluss muss fest an eine eigene Sicherung (16A) mit separater Leitung mit 2,5 mm² angeschlossen werden.</p> <p>Hierzu den mitgelieferten Stecker verdrahten und in die an der Station befestigte Buchse einstecken.</p> <p>STB – Sicherheitstemperaturbegrenzer nach Auslösen hier zurücksetzen.</p> <p>Der BUS-Anschluss ist verpolungssicher.</p>
------------------------------------------------------------------------------------	------------------------------------------------------------------------------------------------------------------------------------------------------------------------------------------------------------------------------------------------------------------------------------------------------------------------------------------------------------------------------

Weitere Details entnehmen Sie der separaten Regulationsanleitung.

Fühlerbelegung

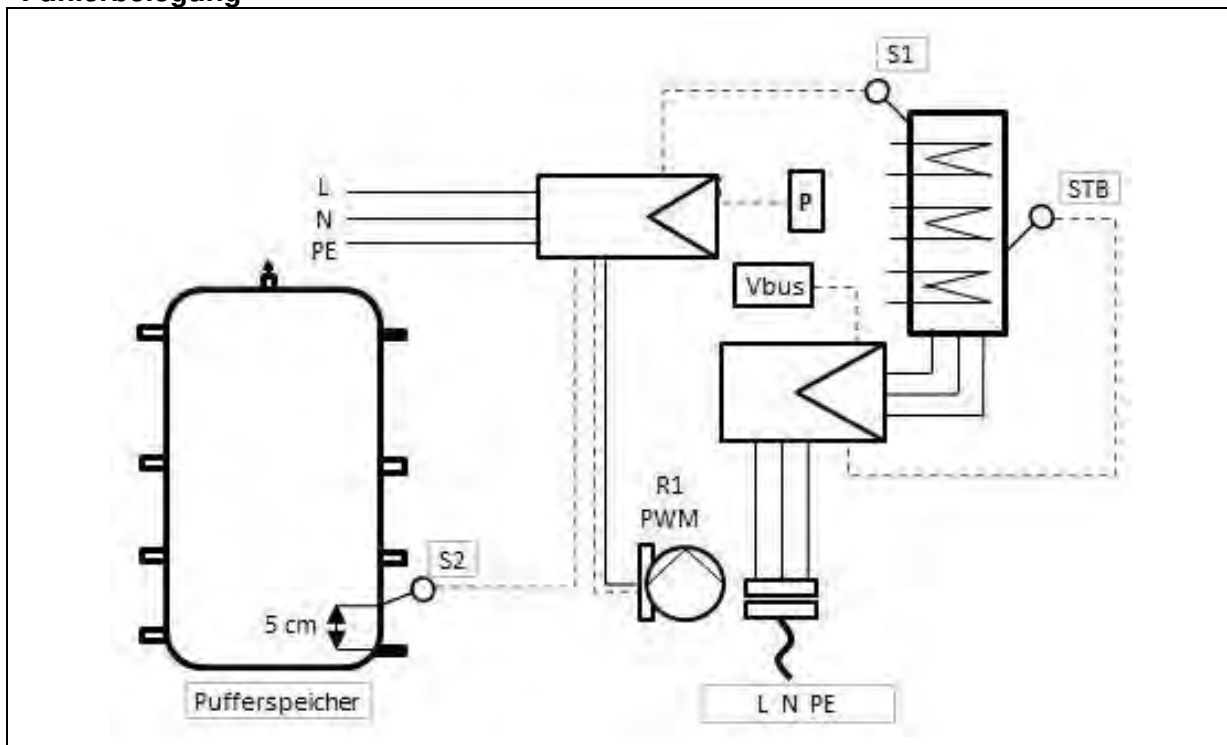

- S1 Temperaturfühler eTherm
- S2 Temperaturfühler Speicher unten
- STB Temperaturfühler Sicherheitstemperaturbegrenzer
- R1 Pumpe
- Vbus Kommunikationsleitung zum Sensormodul

Sensorposition Speicher-unten Sensor S2:

- 5 cm oberhalb des RL-Anschlusses der eTherm P+

ODER

- In die unterste am Speicher vorhandene Tauchhülse

Die Messeinheit **tubra®-eTherm P3+ Sensor** im Hausanschlussschrank vor dem Einspeisezähler montieren und mit der Regelung **tubra®-eTherm P3+ Controller** über den V-BUS verbinden.

5.4 Kaskadierung

5.4.1 Hydraulischer Anschluss

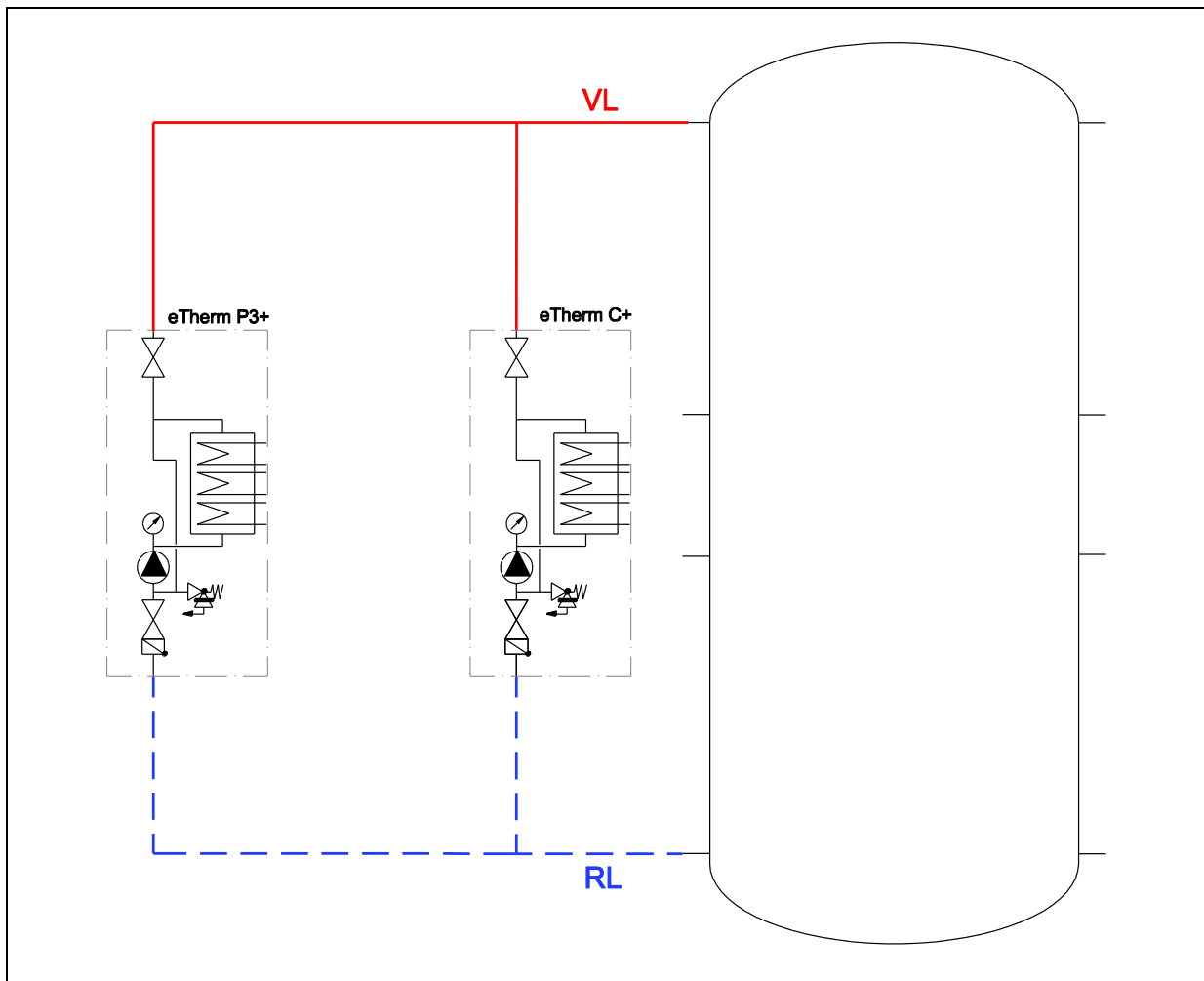

	eTherm P3+	eTherm C+		
		Relais R3	Relais R2	
		Heizelement C3	Heizelement C2	Heizelement C1
0-3 kW	x			
0-6 kW	x	x		
0-9 kW	x	x	x	
0-12 kW	x	x	x	x

Als Kaskade **tubra®-eTherm P3+** und **tubra®-eTherm C+** können bis zu 12.000 W thermische Leistung in den Hydraulikeinheiten umgesetzt werden.

Wahlfunktion externer Verbraucher: Relais R3 mit 3 kW

Wahlfunktion externer Verbraucher 2: Relais R2 mit 3 kW oder 6 kW

5.4.2 Umwälzpumpe

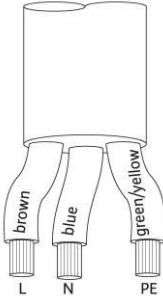
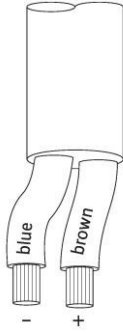
Elektrischer Anschluss Pumpe	Anschluss PWM
 <p>L = braun N = blau PE = grün/gelb</p>	 <p>+ = braun - = blau</p>

6 Inbetriebnahme

Voraussetzung für die Inbetriebnahme ist eine vollständige Installation aller hydraulischen und elektrischen Komponenten.

6.1 Dichtheitsprüfung und Füllen der Anlage

Alle Bauteile der Anlage inkl. aller werksseitig vorgefertigten Elemente und Stationen auf Dichtheit überprüfen und bei eventuellen Undichtigkeiten entsprechend abdichten. Dabei den Prüfdruck und die Prüfdauer dem jeweiligen Verrohrungssystem und dem jeweiligen Betriebsdruck anpassen.

Das Heizungssystem nur mit filtriertem, eventuell aufbereitetem Wasser nach VDI 2035 befüllen und Anlage vollständig entlüften.

6.2 Erstinbetriebnahme

Bitte beachten Sie hierzu die entsprechende Anleitung der Regelung.



Gefahr!

Das System muss vor der ersten elektrischen Inbetriebnahme mit Wasser gefüllt und entlüftet werden.

Arbeitsschritt	Vorgehensweise	OK
Vorbereitung und Kontrolle	<ul style="list-style-type: none"> • Optische Kontrolle der Installation. • Sind alle Fühler an der richtigen Stelle installiert und angeschlossen? • Sind alle Ausgänge angeschlossen? 	<input type="checkbox"/> <input type="checkbox"/> <input type="checkbox"/>
Regler einschalten	Den Regler mit Spannung versorgen.	<input type="checkbox"/>
Regler einstellen	Bitte Anleitung der Regelung beachten. <ul style="list-style-type: none"> • Zieltemperatur wählen • Speichermaximaltemperatur wählen • Inbetriebnahme-Routine starten 	

7 Bedienung

7.1 Regelung

Beachten Sie hierzu die Montage- und Bedienungsanleitung der verwendeten Regelung.

7.2 Schwerkraftbremse

Zur Verhinderung von Fehlzirkulationen ist eine Schwerkraftbremse (SKB) im unteren Kreuzstück (RL) integriert.

7.3 Einstellungen

Zieltemperatur und Speichermaximaltemperatur einstellen.

Beachten Sie hierzu die Montage- und Bedienungsanleitung der verwendeten Regelung.



8 **Wartung / Service**

Der Hersteller empfiehlt eine Wartung in der Form einer Funktions- und Sichtkontrolle durch autorisiertes Fachpersonal. Abhängig von der Wasserqualität und dem Alter der Anlage sollte das Wartungsintervall zwischen 1 und 3 Jahren liegen.

Dazu müssen die Einstellungen gemäß Inbetriebnahmeprotokoll überprüft werden.

Im Handbetrieb muss die **tubra[®]-eTherm P3+** mit unterschiedlichen Heizleistungen betrieben werden und die Funktion kontrolliert werden.

Komponenten	Überprüfung
Elektroheizelement	Bei maximaler Heizleistung sollte die Erwärmung ohne Siedegeräusche ablaufen, anderenfalls das Elektroheizelement reinigen, ggf. entkalken.

9 Störungen, Ursachen und Beseitigung

Liegt eine Fehlermeldung vor, wird diese im Display der Regelung angezeigt.
Bitte beachten Sie hierzu die entsprechende Anleitung der Regelung.

Störung	Mögliche Ursache	Behebung
Zu geringer Volumenstrom (Δt zu hoch)	Elektroheizelement verschmutzt / verkalkt	Reinigen, ggf. entkalken oder austauschen
	Pumpe defekt	Pumpe austauschen
	Regellogik der Pumpe nicht in Ordnung	Sensorpositionen und Funktion prüfen, ggf. austauschen
Zieltemperatur nicht erreicht	Sensor defekt	Sensoren prüfen, ggf. ersetzen
Keine Erwärmung des Heizelements	Speichermaximaltemperatur erreicht	System beobachten, Wiedereinschalten abwarten
	Drucksensor ausgelöst	Betriebsdruck auf > 1,2 bar erhöhen
	STB ausgelöst	Zurücksetzen Sollte der STB ausgelöst werden muss die Ursache durch einen Fachhandwerker ermittelt werden. Anschließend ist eine vollständige Inbetriebnahme mit Kontrolle aller Funktionen erforderlich.
	Fühler S1 defekt → Fühler S1 ersetzen	
	Heizstab defekt	Heizstab prüfen, ggf. austauschen
Siedegeräusche des Heizelements	Keine Erwärmung des Heizelements -> Sicherung hat ausgelöst	Elektrik prüfen, Sicherung wieder einschalten.
	Heizstab verkalkt	Heizstab entkalken
	Luft in der Anlage	Automatikentlüfter installieren
	Druckverlust zum Pufferspeicher zu hoch	Nicht erforderliche Armaturen entfernen bzw. Rohrleitungsdimension erhöhen

LED	Bedeutung	Betriebszustand	Ursache	Beseitigung
leuchtet grün	Pumpe in Betrieb	Pumpe läuft entsprechend ihrer Einstellung	Normalbetrieb	
blinkt schnell grün	PWM Version	Pumpe im Standby	Normalbetrieb	
blinkt rot/grün	Pumpe ist betriebsbereit, läuft aber nicht	Pumpe läuft eigenständig wieder an, sobald der Fehler nicht mehr ansteht	1. Unterspannung $U < 160 \text{ V}$ Überspannung $U > 253 \text{ V}$	1. Spannungsversorgung überprüfen $195 \text{ V} < U < 253 \text{ V}$
			2. Modul-Übertemperatur: Motortemperatur zu hoch	2. Medien- und Umgebungstemperatur überprüfen
blinkt rot	Pumpe außer Funktion	Pumpe steht (blockiert)	Pumpe läuft nicht eigenständig wieder an	Pumpe austauschen
LED aus	Keine Spannungsversorgung	Elektronik hat keine Spannung	1. Verbindung Regler zu Pumpe unterbrochen	1. Kabelanschluss überprüfen
			2. LED ist defekt	2. Prüfen, ob die Pumpe läuft
			3. Elektronik ist defekt	3. Pumpe austauschen

Lässt sich die Betriebsstörung nicht beheben, wenden Sie sich bitte an das Fachhandwerk oder an den Wilo-Werkskundendienst.



10 Außerbetriebnahme

Vorübergehend

Bleibt die elektrothermische Station **tubra®-eTherm P3+** über längere Zeit außer Betrieb und in einem frostgefährdeten Raum, muss die Stromversorgung unterbrochen und die Anlage vollständig entleert werden. Dazu lösen Sie die untere Verschraubung des Heizelements und die untere Pumpenschraubung, um diese vollständig zu entleeren.

Endgültig

Wird die elektrothermische Station **tubra®-eTherm P3+** endgültig außer Betrieb genommen, so ist die Stromversorgung aller betroffenen Anlagenteile zu unterbrechen und alle betroffenen Leitungen und Anlagenteile sind vollständig zu entleeren. Dazu lösen Sie die untere Verschraubung des Heizelements und die untere Pumpenschraubung, um diese vollständig zu entleeren.

Eine endgültige Außerbetriebnahme, Demontage und Entsorgung darf nur durch ausgebildetes Fachpersonal durchgeführt werden. Bauteile und Materialien müssen entsprechend den aktuellen Vorschriften entsorgt werden.



Konformitätserklärung Declaration of Conformity

Hersteller:
Manufacturer:
D – 33659 Bielefeld

Gebr. Tuxhorn GmbH & Co.KG
Senner Straße 171



Produktbezeichnung:
Product description:

tubra®-eTherm P3+/P9+
(controller / power / sensor)
tubra®-eTherm C3+/C9+; tubra®-eTherm S3/S9

EU-Richtlinien:

EC-Directives:

Directive 2014/30/EU - EMC

Directive 2014/35/EU

Directive 2009/125/EC

Directive 2011/65/EU

electromagnetic compatibility

electrical equipment designed for use within certain voltage limits

ecodesign requirements for energy-related products

certain hazardous substances in electrical and electronic equipment RoHS

Angewendete Normen:

Standards:

DIN EN 16297-1/3:2013-04

EN 55014-1:2021

EN 55014-2:2021

EN 60335-1:2024; VDE 0700-1:2024

+AC:2014+A11:2014+A13:2017+A1:2019

+A2:2019+A14:2019+A15:2021+A16:2023

DIN EN 60335-2-35 VDE 0700-

35:2022-10 + A1:2019 + A2:2021

DIN EN 60730-1 VDE 0631-1:2021-06

DIN EN IEC 60730-2-9

VDE 0631-2-9:2021-01

EN ICE 61000-6-3:2021

EN ICE 61000-6-4:2019

EN IEC 61000-6-1/2:2019

DIN EN ISO 9001:2015-11

DIN EN IEC 63000:2019-05

VDE 0042-12:2019-05

Pumpe / Regler / Heizelement

Pumps - Rotodynamic pumps - Glandless circulators - Part 1/3

Electromagnetic compatibility - Part 1

Electromagnetic compatibility - Part 2

Household and similar electrical appliances

Sicherheit elektrischer Geräte für den Hausgebrauch und ähnliche Zwecke, Besondere Anforderungen für Durchflusserwärmer

Automatic electrical controls

Automatic electrical controls - Part 2-9

Electromagnetic compatibility (EMC) - Part 6-3

Electromagnetic compatibility (EMV) - Teil 6-4

Electromagnetic compatibility (EMC) - Part 6-1 / Part 6-2

Quality management systems - Requirements (ISO 9001:2015)

Assessment of electronic products with respect to the restriction of hazardous substances

Wir, die Gebr. Tuxhorn GmbH & Co.KG, erklären hiermit, dass die oben genannten Produkte den aufgeführten Bestimmungen entsprechen. Bei einer nicht mit uns abgestimmten Änderung des Produktes verliert diese Erklärung ihre Gültigkeit. Die Sicherheitshinweise in der Betriebs- und Bedienungsanleitung sind zu beachten.

We, Gebr. Tuxhorn GmbH & Co. KG, hereby declare that the above-mentioned products comply with the provisions listed. This declaration becomes invalid if the product is modified without our agreement. The safety instructions in the operating instructions must be observed.

Bielefeld, 08.07.2024



Stephan Krebs
Geschäftsführer

i.A. Frank Thole
Leiter Produktmanagement

Diese Erklärung beinhaltet keine Zusicherung von Eigenschaften.
This declaration does not include any guarantee of product properties.

Händler

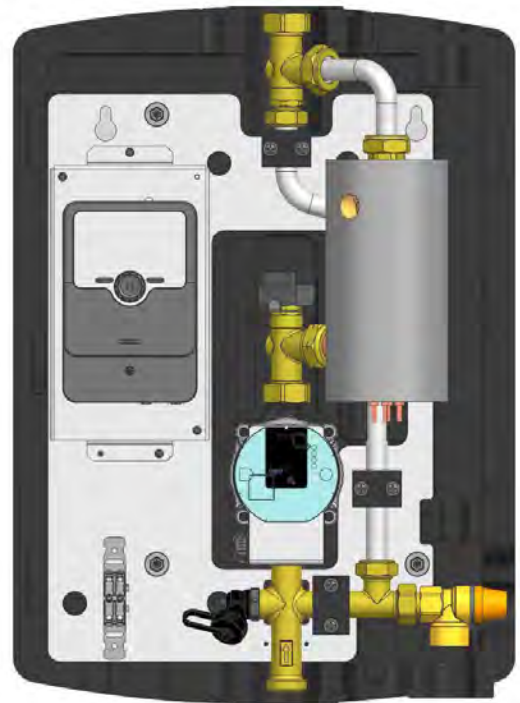



tubra[®] - eTherm P3+

Montage- und Bedienungsanleitung

Content

1	Introduction.....	3
1.1	Intended purpose.....	3
1.2	Safety instructions	3
1.3	Applicable documents.....	5
1.4	Delivery and transport.....	5
2	Functional description.....	6
2.1	System setup in the installation	6
2.2	Functional description	6
3	Layout – scope of delivery	7
4	Technical specifications.....	8
4.1	General.....	8
4.2	Dimensions / required space	8
4.3	Pressure loss / characteristic curve	9
4.4	Connections.....	9
5	Assembly	10
5.1	Wall-mounted assembly	10
5.2	Hydraulic connection buffer storage tank.....	10
5.3	Electrical connection.....	11
5.4	Cascading.....	13
6	Start-up.....	14
6.1	Leak testing and filling the system	14
6.2	Initial commissioning.....	15
7	Operation.....	15
7.1	Control unit	15
7.2	Gravity brake	15
7.3	Settings.....	15
8	Maintenance / service.....	16
9	Malfunctions, causes and troubleshooting.....	17
10	Decommissioning	18



1 Introduction

This manual describes the installation process for the **tubra®-eTherm P3+** electro-thermal station, as well as its operating and maintenance procedures.

This manual is intended for trained specialists with an adequate level of expertise in handling heating systems, water pipe installations and electrical installations. The installation and commissioning procedures should only be conducted by qualified, specialist personnel.

The station must only be installed and operated in dry areas that are protected from frost. Read this manual carefully before starting any installation work. Non-compliance will invalidate all claims under the guarantee and warranty.

Illustrations are symbolic and may differ from product to product. Subject to technical changes and errors.

This installation and operating manual must not be reproduced or made available to third parties without prior written consent (section 2 German Copyright Act, section 823 Civil Code).

1.1 Intended purpose

The **tubra®-eTherm P3+** electro-thermal station is exclusively used to heat water with an electrical heating element in a through-flow circuit. Only heating water (HW) as per VDI 2035 may be heated.

1.2 Safety instructions

In addition to country-specific guidelines and local directives, the following technical regulations must also be taken into account:

- DIN 1988 Technical rules for drinking water installations
- DIN 18 380 Heating systems and central water heating systems
- VDI 2035 Scale formation in drinking water heating systems and hot water systems
- DIN 4753 Water heaters and water heating installations for drinking water and service water
- DIN EN 60335-1 Household and similar electrical appliances - Safety Part 1: General requirements
- DIN EN 60335-2 Household and similar electrical appliances - Safety Part 2: Particular requirements
- TrinkwV Drinking Water Ordinance
- DVGW W551 Drinking water heating and drinking water pipeline systems
- BGV Accident prevention regulations of workers' compensation associations
- VDE 0100 Series of standards on the use of electrical equipment of machines
- EN 806-2 Technical regulations for drinking water installations – requirements for components, equipment and materials
- Local energy and water suppliers' rules
- Details on the type plate
- Technical specifications



As the system can reach temperatures > 60°C, there is a risk of scalding and burning through contact with the components.

Target group

These instructions are intended for users of the heating system.

This device can be used by children aged from 3 years and above and by persons with reduced physical, sensory or mental capabilities or lack of experience and knowledge if they have been given supervision or instruction concerning use of the appliance in a safe way and understand the hazards involved.

 Caution	<p>Supervise children in the vicinity of the appliance.</p> <ul style="list-style-type: none"> - Children must not play with the appliance. - Cleaning and user maintenance must not be carried out by children without supervision.
-----------------------------------------------------------------------------------------------------	--------------------------------------------------------------------------------------------------------------------------------------------------------------------------------------------------------------------------------------------------------------

Connecting the device

This user manual is intended for users of the heating system.

- The device may only be connected and put into operation by authorized specialists.
- Observe the specified electrical connection conditions.
- Changes to the existing installation may only be carried out by authorized specialists.

 Danger	<p>Improperly performed work on the heating system can lead to life-threatening accidents.</p> <ul style="list-style-type: none"> - Electrical work may only be carried out by qualified electricians.
----------------------------------------------------------------------------------------------------	-----------------------------------------------------------------------------------------------------------------------------------------------------------------------------------------------------------------------

Working on the system

- Only carry out settings and work on the appliance in accordance with the specifications in these operating instructions. Further work on the appliance may only be carried out by authorized specialists.
- Do not open the appliance.
- Do not remove the housing.
- Do not modify or remove installed accessories or attachments.
- Do not open or tighten pipe connections.

 Danger	<p>Hot surfaces and fluids can cause burns or scalding.</p> <ul style="list-style-type: none"> - Do not open the appliance. - Never touch hot surfaces on the appliance, fittings or pipework.
------------------------------------------------------------------------------------------------------	------------------------------------------------------------------------------------------------------------------------------------------------------------------------------------------------------------------------

Damage at the appliance

 Danger	<p>Damaged appliances endanger your safety.</p> <ul style="list-style-type: none"> - Check the appliance for external damage. - Do not operate a damaged appliance.
------------------------------------------------------------------------------------------------------	---------------------------------------------------------------------------------------------------------------------------------------------------------------------------------------------

Water leaking from the appliance

 Danger	<p>If water escapes from the appliance there is a risk of electric shock.</p> <ul style="list-style-type: none"> - Switch OFF the heating system at the external isolator (e.g. fuse box, domestic distribution board). - Notify a specialist heating company.
------------------------------------------------------------------------------------------------------	----------------------------------------------------------------------------------------------------------------------------------------------------------------------------------------------------------------------------------------------------------------------------------------

 Danger	<p>If water escapes from the appliance there is a risk of scalding.</p> <ul style="list-style-type: none"> - Never touch hot heating water.
------------------------------------------------------------------------------------------------------	------------------------------------------------------------------------------------------------------------------------------------------------------------





Procedure in the event of faults in the heating system

 Danger	Fault messages indicate defects on the heating system. Faults that are not rectified can have life-threatening consequences. <ul style="list-style-type: none"> - Do not acknowledge fault messages several times at short intervals. - Notify a specialist company so that they can analyze the cause and rectify the fault.
---------------------------------------------------------------------------------------------	-------------------------------------------------------------------------------------------------------------------------------------------------------------------------------------------------------------------------------------------------------------------------------------------------------------------------------------------------------

Requirements for the installation site

 Danger	Do not make any subsequent changes to the structural conditions that could affect safe operation (e.g. cable routing, cladding or partition walls).
---------------------------------------------------------------------------------------------	-----------------------------------------------------------------------------------------------------------------------------------------------------

 Danger	Highly flammable liquids and materials (e.g. petrol, solvents and cleaning agents, paints or paper) can cause deflagrations and fires. Do not store or use such substances in the boiler room or in the immediate vicinity of the heating system.
---------------------------------------------------------------------------------------------	---------------------------------------------------------------------------------------------------------------------------------------------------------------------------------------------------------------------------------------------------

 Caution	Impermissible ambient conditions can cause damage to the heating system and jeopardize safe operation. <ul style="list-style-type: none"> - Ensure an ambient temperature between 0 °C and 35 °C. - Avoid air pollution from halogenated hydrocarbons (e.g. contained in paints, solvents and cleaning agents) and heavy dust accumulation (e.g. from sanding work). - Avoid permanently high humidity (e.g. due to permanent drying of laundry).
----------------------------------------------------------------------------------------------	------------------------------------------------------------------------------------------------------------------------------------------------------------------------------------------------------------------------------------------------------------------------------------------------------------------------------------------------------------------------------------------------------------------------------------------------------------------------------------

Auxiliary components, spare and wearing parts

 Caution	Components that have not been tested with the heating system can cause damage to the heating system or impair its functions. Installation or replacement must only be carried out by a specialist company.
------------------------------------------------------------------------------------------------	------------------------------------------------------------------------------------------------------------------------------------------------------------------------------------------------------------

1.3 Applicable documents

Please also observe the installation and operating instructions for the components used, e.g. the control unit.

1.4 Delivery and transport

Check to make sure the product is complete and undamaged immediately after receipt. Any damage or complaints must be reported immediately.



2 Functional description

2.1 System setup in the installation

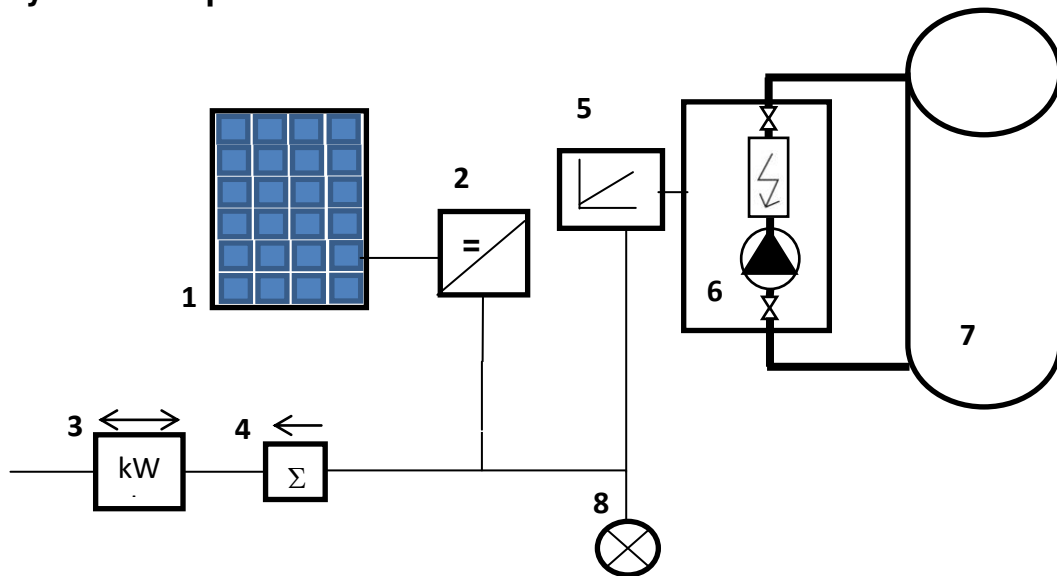

- 1 Photovoltaic system
- 2 Inverter
- 3 Electricity meter (draw, infeed)
- 4 tubra®-eTherm P3+ sensor (infeed power measurement)
- 5 tubra®-eTherm P3+ power (power modulation)
- 6 tubra®-eTherm P3+ with tubra®-eTherm controller P
- 7 Thermal storage tank
- 8 Domestic consumers (light, standby, ...)

2.2 Functional description

The **tubra®-eTherm P3+** is an electrothermal station for converting photovoltaic electricity into heat and storing this heat in buffer tanks.

With the infinitely variable power control of the **tubra®-eTherm P3+**, surplus electricity can be optimally utilized. The storage tank is charged with an immediately usable temperature level via the speed-controlled charging pump. When the maximum cylinder temperature is reached, charging is terminated.

The advantages are:

- Optimal adjustment thanks to continuously modulating output up to 3000 W
- Layered storage tank loading, even when retrofitting to existing cylinders
- Adjustable target temperature
- Immediately usable heat even with low solar radiation
- Can be retrofitted to any buffer cylinder
- Independent of the PV inverter, energy manager and electricity meter

The control unit consists of the controller (6), the power section (6) and the measuring section (4). The supplied measuring section measures the current flow directly upstream of the electricity meter (3). If a sufficiently high output is detected, this photovoltaic current can be used for electric water heating. The controller uses the power unit to regulate the power levels in the electrothermal station for heating the cylinder. Thanks to the instantaneous water heater principle with pump speed control, the **tubra®-eTherm P3+** supplies heat at a high temperature level to the storage tank even at low heat output, e.g. on cloudy days. This allows the buffer cylinder to be loaded in layers.

3 Layout – scope of delivery

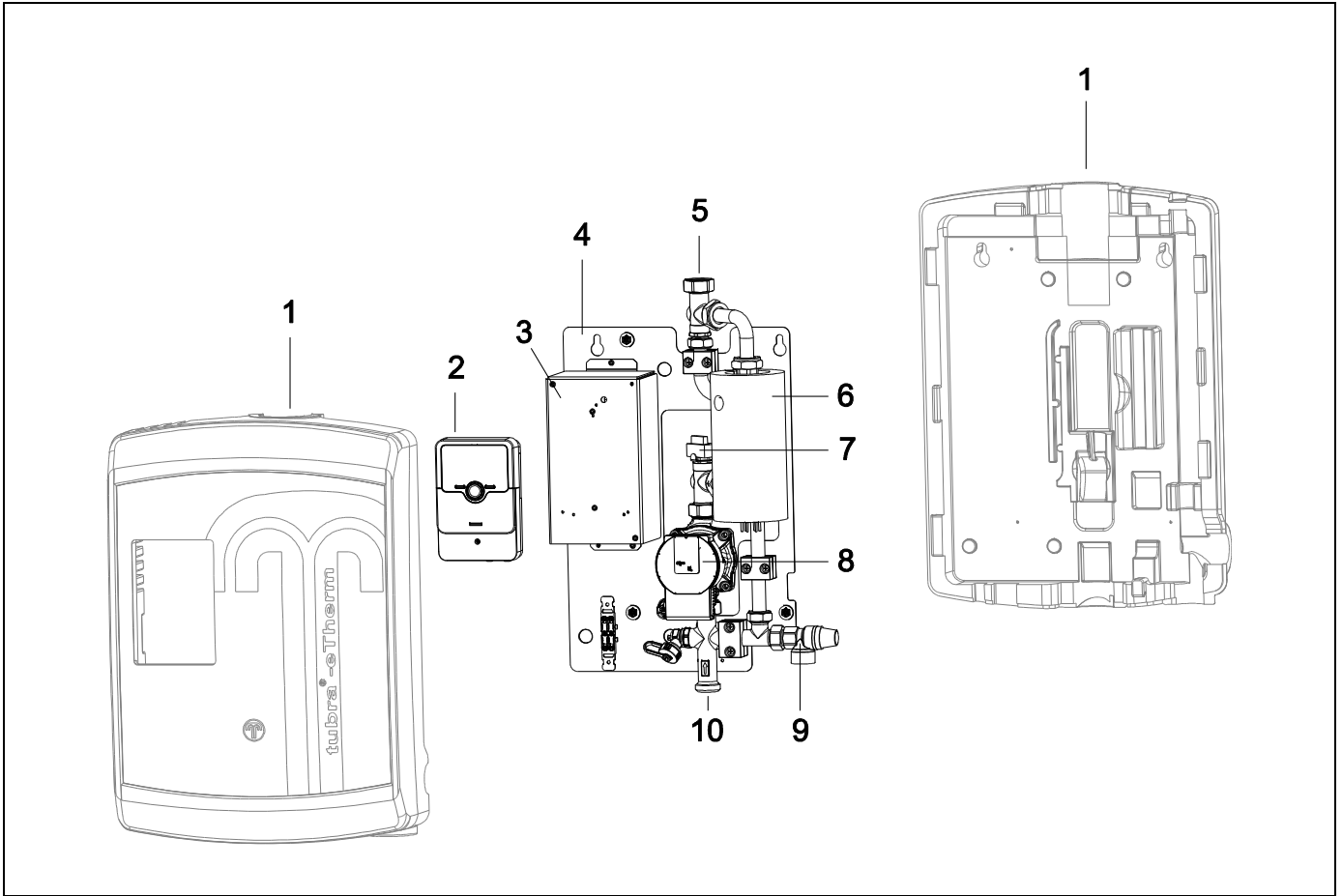

Item	Designation
1	Insulating shell
2	Control unit
3	Connection box for safety temperature limiter and contactors
4	Base plate
5	Ball valve supply line (VL)
6	Electric heating element + insulating shell
7	Pressure switch
8	Pump
9	Cross piece with safety valve 3bar and backflow preventer
10	Ball valve return line (RL)

4 Technical specifications

4.1 General

Designation / type	tubra®-eTherm P3+
Rated output/current	0 – 3 kW (13 A)
Electrical connection	1/PE 230 V AC 50 – 60 Hz
Required cable cross-section	2,5 mm ²
Rated capacity	0,2 l
Heating element	0,8 kW / 0,8 kW / 1,4 kW
Flow rate	2 l/h – 300 l/h
Pressure loss	0,6 bar at 300 l/h
Temperature setting range	30 °C – 80 °C
Water connection	Rp 3/4" IG
Weight (with water fill)	14 kg
Degree of protection	IP 22

Designation / type		tubra®-eTherm P3+ 951.15.00.00
Version		Heating water
Rated output		0 - 3 kW
Max. operating pressure		3 bar
Max. operating temperature		95 °C
Circulation pump		Wilo Para ST 15/7 iPWM2 Power consumption: 3-45 W
Materials	Housing/connecting components	CW617N (2.0402)
	Heating element	Copper version
	Seals	EPDM
	Insulation	EPP- foam 0,038 W/mK

4.2 Dimensions / required space

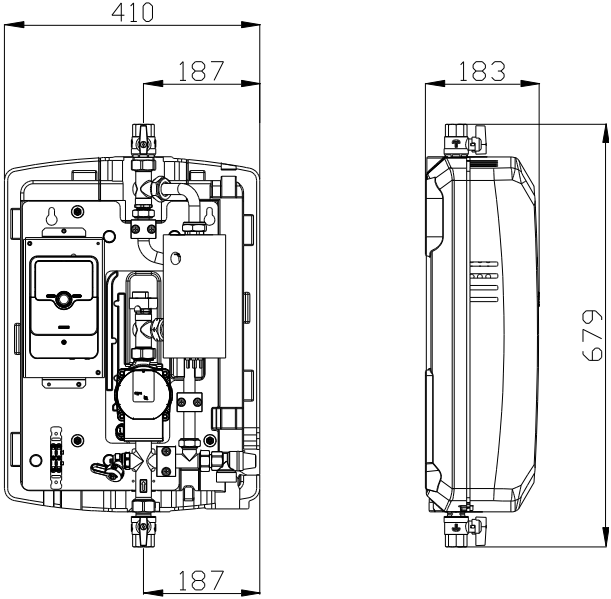
	<p>Dimensions and minimum space requirement for installation and maintenance work</p>
-------------------------------------------------------------------------------------	---------------------------------------------------------------------------------------

4.3 Pressure loss / characteristic curve

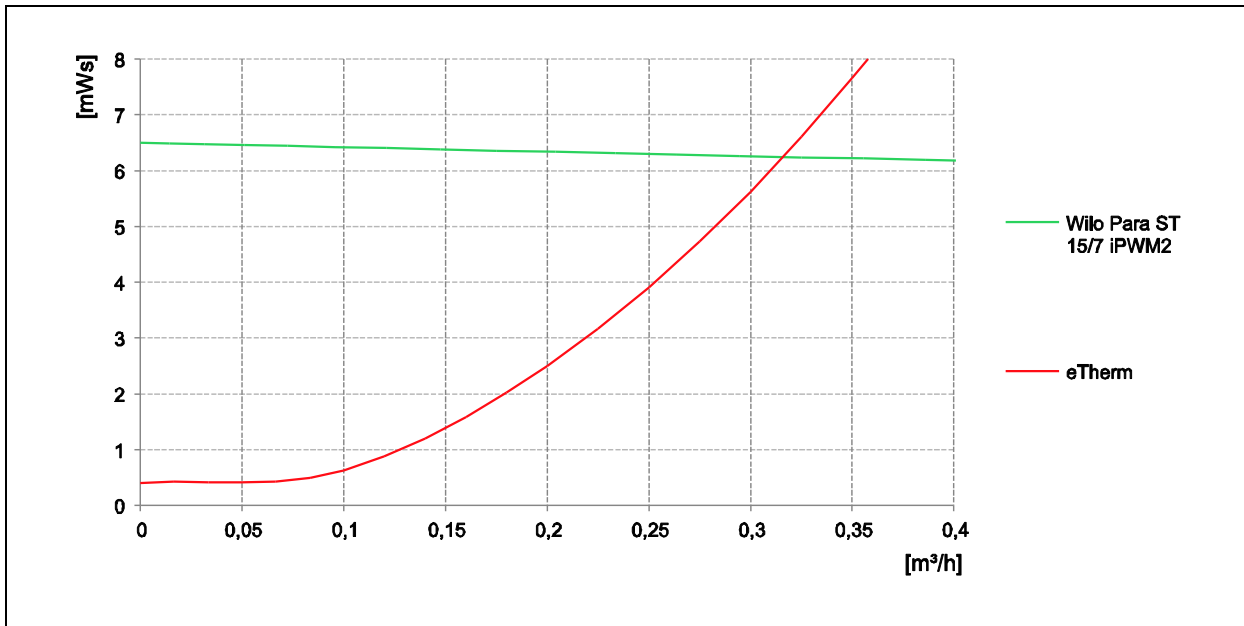

4.4 Connections

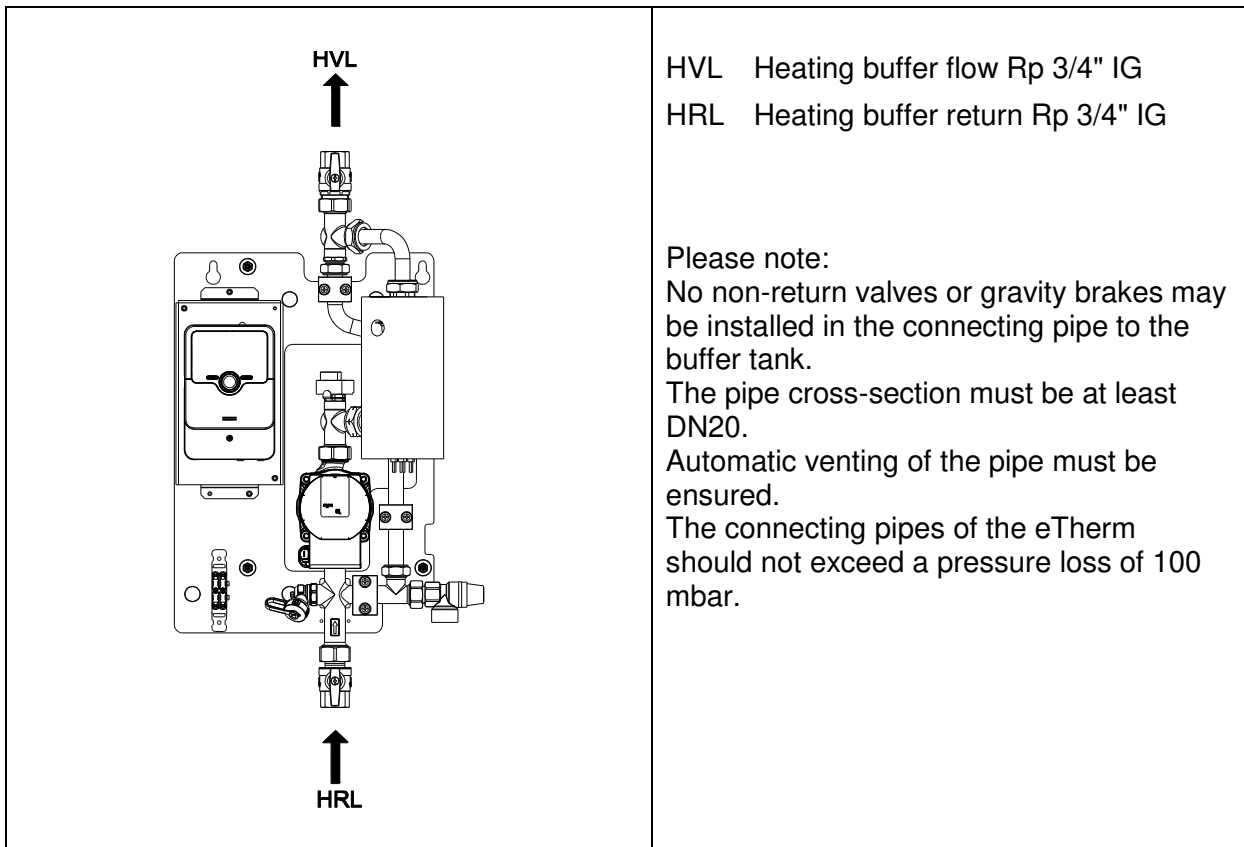

5 Assembly

5.1 Wall-mounted assembly

	<p>Mark two holes \varnothing 10mm as shown in the adjacent illustration, drill and insert expansion plugs. Screw in the upper screw with washer until the screw head is approx. 1 cm away from the wall. Suspend the station, align with a spirit level and fix with the second screw and washer. Tighten both screws evenly.</p>
--	-------------------------------------------------------------------------------------------------------------------------------------------------------------------------------------------------------------------------------------------------------------------------------------------------------------------------------------------------------------

5.2 Hydraulic connection buffer storage tank

<p>tubra®-eTherm P3+ with drinking water storage tank</p>	<p>tubra®-eTherm P3+ with buffer storage tank</p>
<p>This is a sample illustration which does not claim to be exhaustive; it does not replace specialist planning.</p>	
<p>Designation</p>	<p>Description</p>
<p>VL</p>	<p>Supply</p>
<p>RL</p>	<p>Return side</p>

5.3 Electrical connection

5.3.1 General

Work on the electrical system and the opening of electrical enclosures may only be carried out when the power supply is switched off and only by authorized specialist personnel. Ensure correct terminal assignment and polarity for the connections. Protect the control unit and electrical components from overvoltage.

 Danger!	<p>Risk of fatal electric shock as a result of incorrect electrical connections.</p> <ul style="list-style-type: none"> → Electrical connections must exclusively be created by electricians approved by energy suppliers and as per the locally applicable regulations. → Disconnect the supply voltage prior to conducting any work.
-----------------------------------------------------------------------------------------------------	----------------------------------------------------------------------------------------------------------------------------------------------------------------------------------------------------------------------------------------------------------------------------------------------------------------------------------------------------------------

The station is completely pre-assembled and pre-wired at the factory. For commissioning, connect the mains cable and establish the bus connection to the control unit.

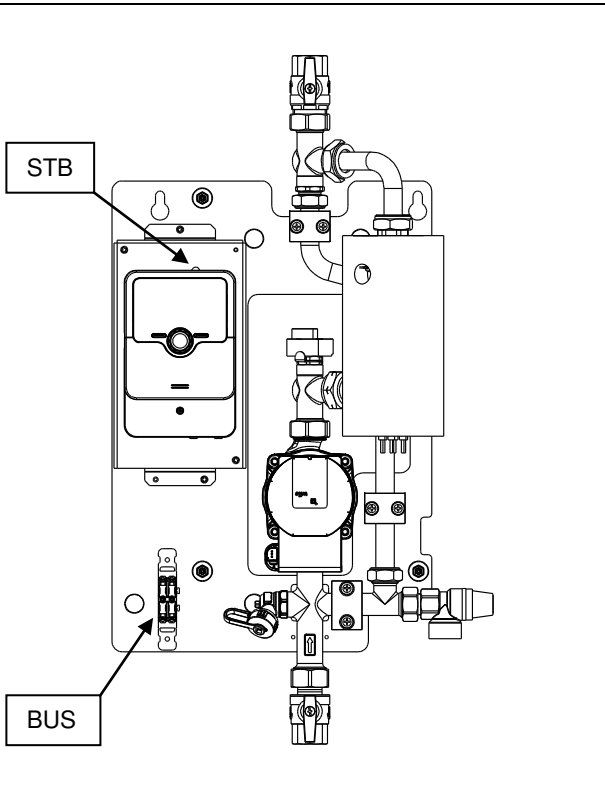
	<p>The mains connection must be permanently connected to a separate fuse (16A) with a separate cable of 2.5 mm² cable.</p> <p>To do this, wire the supplied plug and plug it into the socket attached to the station.</p> <p>STB – Reset safety temperature limiter after triggering here.</p> <p>The BUS connection is protected against polarity reversal.</p>
------------------------------------------------------------------------------------	-----------------------------------------------------------------------------------------------------------------------------------------------------------------------------------------------------------------------------------------------------------------------------------------------------------------------------------------------------------------------------

Further details can be found in the separate control instructions.

Sensor assignment

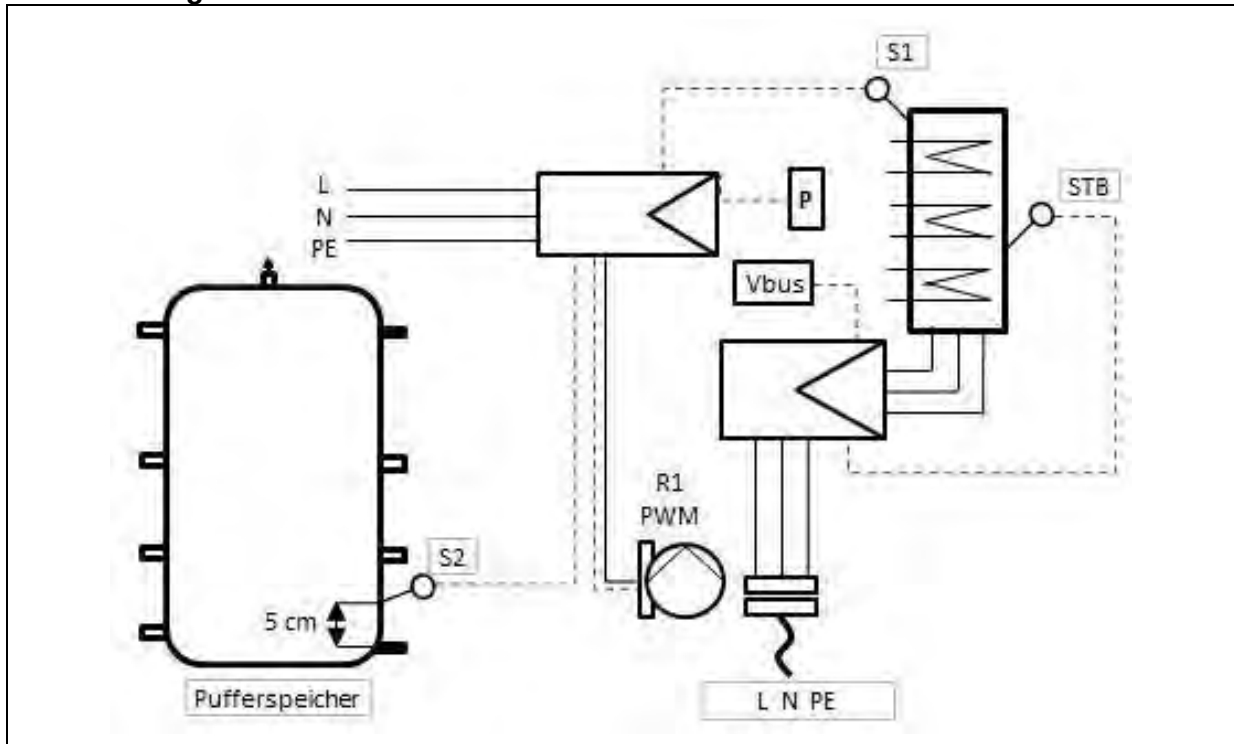

- S1 Temperature sensor eTherm
- S2 Temperature sensor storage tank bottom
- STB Temperature sensor Safety temperature limiter
- R1 Pump
- Vbus Communication line to the sensor module

Sensor position storage tank-bottom sensor S2:

- 5 cm above the return connection of the eTherm P+

OR

- In the lowest immersion sleeve on the storage tank

Install the **tubra®-eTherm P3+ sensor** measuring unit in the house connection cabinet in front of the feed meter and connect it to the SM base in the **tubra®-eTherm P3+** controller.

5.4 Cascading

5.4.1 Hydraulic connection

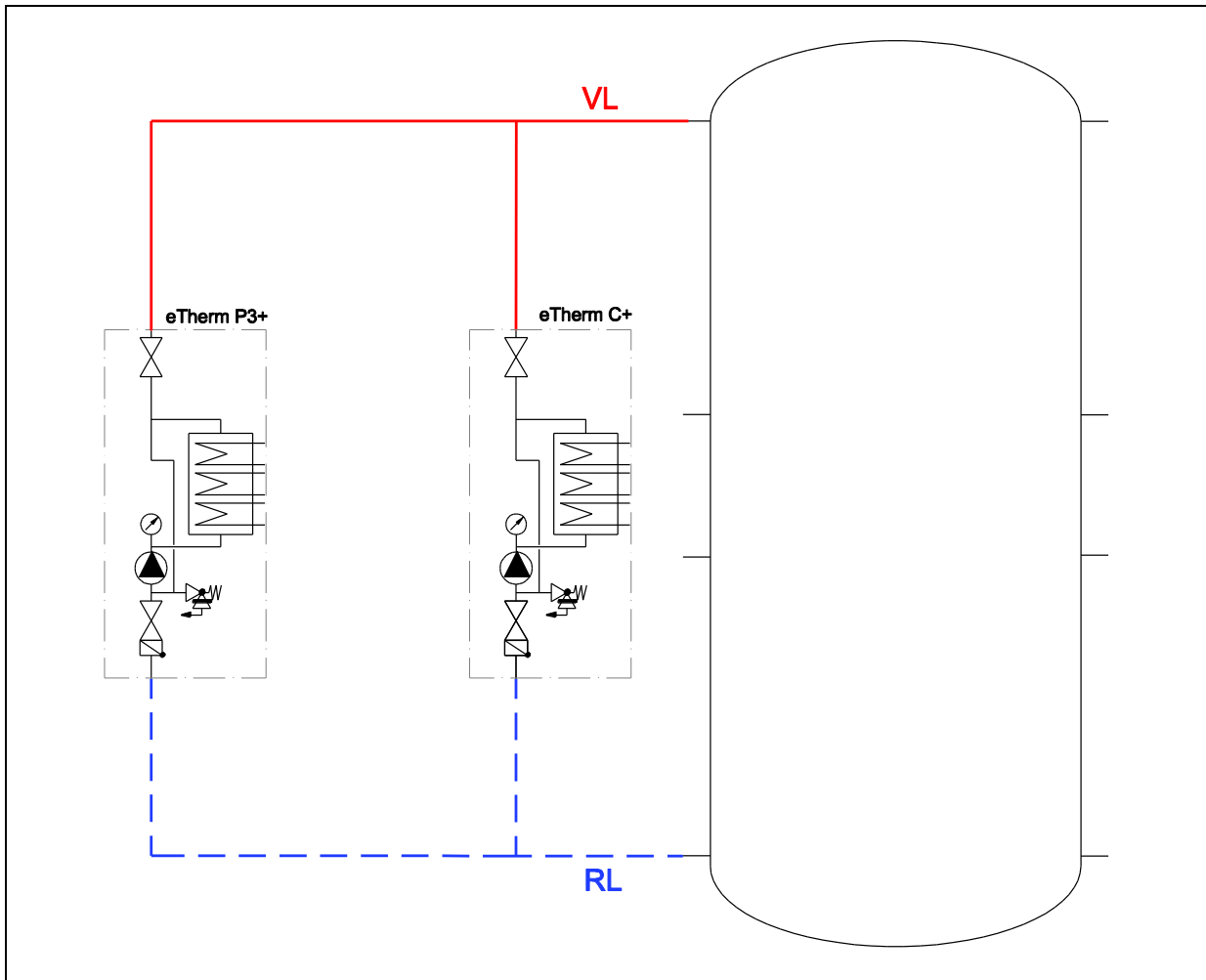

	eTherm P3+	eTherm C+		
		Relay R3	Relay R2	
		Heating element C3	Heating element C2	Heating element C1
0-3 kW	x			
0-6 kW	x	x		
0-9 kW	x	x	x	
0-12 kW	x	x	x	x

By cascading the tubra®-eTherm P3+ station with three further tubra®-eTherm C+ stations, up to 12000 W thermal output can be implemented in the hydraulic units.

Selector function external consumer: Relay R3 with 3 kW

Selector function external consumer 2: Relay R2 with 3 kW or 6 kW

5.4.2 Circulation pump

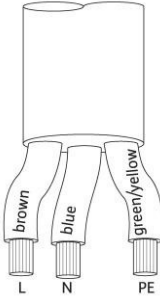
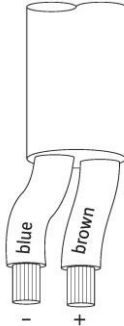
Electrical connection pump	PWM connection
 <p>L = brown N = blue PE = green/yellow</p>	 <p>+ = brown - = blue</p>

6 Start-up

Complete installation of all hydraulic and electrical components is a precondition for commissioning.

6.1 Leak testing and filling the system

Check all system components, including all pre-fabricated elements and stations, to ensure they are leak-tight; seal any detected leaks accordingly. When doing so, adapt the test pressure and test duration to match the respective piping system and the respective operating pressure.

Only fill the heating system with filtered, possibly treated water as per VDI 2035 and completely bleed the system.

6.2 Initial commissioning

Please observe the corresponding instructions for the control unit.



The system must be filled with water and ventilate before initial electrical start-up.

Step	Procedure	OK
Preparation and control	<ul style="list-style-type: none"> • Visual inspection of the installation. • Are all sensors installed and connected in the correct position? • Are all outputs connected? 	<input type="checkbox"/> <input type="checkbox"/> <input type="checkbox"/>
Switch on the controller	Supply the controller with voltage.	<input type="checkbox"/>
Set controller	Please follow the control instructions. <ul style="list-style-type: none"> • Select target temperature • Select maximum cylinder temperature • Start commissioning routine 	_____ _____ -

7 Operation

7.1 Control unit

Observe the installation and operating instructions for the control unit used.

7.2 Gravity brake

A gravity brake is integrated above the pump in the return line to prevent incorrect circulation.

7.3 Settings

Adjust the target temperature and maximum accumulator temperature.
Observe the installation and operating instructions for the control unit used.



8 Maintenance / service

The manufacturer recommends maintenance in the form of a function and visual check by authorised, specialist personnel. Depending on the water quality and the age of the system, the maintenance interval should be between 1 and 3 years.

For this purpose, the settings must be checked in accordance with the commissioning protocol.

In manual mode, the **tubra®-eTherm P3+** must be operated with different heating outputs and the function checked.

Components	Check
Electrical heating element	At maximum heat output, heating should take place without boiling noises, otherwise clean the electric heating element and decalcify if necessary.



9 Malfunctions, causes and troubleshooting

If an error message is output, it appears on the control unit display.

Please observe the corresponding instructions for the control unit.

Malfunction	Possible cause	Remedy
Volume flow rate too low (Δt too high)	Electric heating element dirty / calcified	Clean, descale or replace if necessary
	Pump faulty	Replace pump
	Control logic of the pump not in order	Check sensor positions and function, replace if necessary
Target temperature not reached	Sensor faulty	Check sensors, replace if necessary
Heating element not heating up	Maximum storage tank temperature reached	Monitor system, wait for restart
	Pressure sensor triggered	Increase operating pressure to > 1.2 bar
	STB triggered	Reset
	Sensor S1 faulty → Replace sensor S1	If the STB is triggered, the cause must be determined by a specialist technician. A complete commissioning with a check of all functions is then required.
	Heating element faulty	Check heating element, replace if necessary
Boiling noises from the heating element	No heating of the heating element → fuse has tripped	Check electrical system, switch fuse back on.
	Heating element calcified	Descale the heating element
	Air in the system	Install an automatic air vent
	Pressure loss to buffer tank too high	Remove unnecessary fittings or increase pipe dimensions

LED	Meaning	Operating state	Cause	Elimination
Lit green	Pump operational	Pump running as configured	Normal operation	
Flashing fast green	PWM version	Pump in standby mode	Normal operation	
Flashing red/green	Pump is ready for operation, but not running	Pump will automatically restart once the fault has been eliminated	1. Undervoltage $V < 160$ V	1. Check voltage supply 195 V $< V < 253$ V
			Overvoltage $V > 253$ V	
Flashing red	Pump not working	Pump stopped (blocked)	2. Module overtemperature: Motor temperature too high	2. Check media and ambient temperature
			Pump will not automatically restart	Replace pump
LED off	No voltage supply	Electronics without voltage	1. Controller to pump connection interrupted	1. Check cable connection
			2. LED is defective	2. Check whether the pump is running
			3. Electronics are defective	3. Replace pump

Pump information table: If the malfunction cannot be rectified, please contact a specialist or Wilo factory service.



10 Decommissioning

Temporary

If the **tubra[®]-eTherm P3+** electro-thermal station is decommissioned for a prolonged period and kept in an area that is prone to frost, the power supply must be disconnected and the system drained completely. To do this, loosen the lower screw connection on the heating element and the lower pump screw connection in order to drain them completely.

Final

If the **tubra[®]-eTherm P3+** electro-thermal station is being decommissioned once and for all, the power supply for all of the corresponding system components must be disconnected and all of the relevant lines and components drained completely. To do this, loosen the lower screw connection on the heating element and the lower pump screw connection in order to drain them completely.

The decommissioning, dismantling and disposal processes should only be conducted by qualified, specialist personnel. Components and materials must be disposed of in accordance with the current applicable regulations.



Konformitätserklärung Declaration of Conformity

Hersteller:
Manufacturer:
D – 33659 Bielefeld

Gebr. Tuxhorn GmbH & Co.KG
Senner Straße 171



Produktbezeichnung:
Product description:

tubra®-eTherm P3+/P9+
(controller / power / sensor)
tubra®-eTherm C3+/C9+; tubra®-eTherm S3/S9

EU-Richtlinien:
EC-Directives:

Directive 2014/30/EU - EMC
Directive 2014/35/EU
Directive 2009/125/EC
Directive 2011/65/EU

electromagnetic compatibility
electrical equipment designed for use within certain voltage limits
ecodesign requirements for energy-related products
certain hazardous substances in electrical and electronic equipment RoHS

Angewendete Normen:
Standards:

DIN EN 16297-1/3:2013-04

Pumpe / Regler / Heizelement

EN 55014-1:2021

Pumps - Rotodynamic pumps - Glandless circulators - Part 1/3

EN 55014-2:2021

Electromagnetic compatibility - Part 1

EN 60335-1:2024; VDE 0700-1:2024
+AC:2014+A11:2014+A13:2017+A1:2019
+A2:2019+A14:2019+A15:2021+A16:2023

Electromagnetic compatibility - Part 2

Household and similar electrical appliances

DIN EN 60335-2-35 VDE 0700-35:2022-10 + A1:2019 + A2:2021

Sicherheit elektrischer Geräte für den Hausgebrauch und ähnliche Zwecke, Besondere Anforderungen für Durchflusserwärmer

DIN EN 60730-1 VDE 0631-1:2021-06

Automatic electrical controls

DIN EN IEC 60730-2-9

Automatic electrical controls - Part 2-9

VDE 0631-2-9:2021-01

EN ICE 61000-6-3:2021

Electromagnetic compatibility (EMC) - Part 6-3

EN ICE 61000-6-4:2019

Electromagnetic compatibility (EMV) - Teil 6-4

EN IEC 61000-6-1/2:2019

Electromagnetic compatibility (EMC) - Part 6-1 / Part 6-2

DIN EN ISO 9001:2015-11

Quality management systems - Requirements (ISO 9001:2015)

DIN EN IEC 63000:2019-05

Assessment of electronic products with respect to the restriction of hazardous substances

VDE 0042-12:2019-05

Wir, die Gebr. Tuxhorn GmbH & Co.KG, erklären hiermit, dass die oben genannten Produkte den aufgeführten Bestimmungen entsprechen. Bei einer nicht mit uns abgestimmten Änderung des Produktes verliert diese Erklärung ihre Gültigkeit. Die Sicherheitshinweise in der Betriebs- und Bedienungsanleitung sind zu beachten.

We, Gebr. Tuxhorn GmbH & Co. KG, hereby declare that the above-mentioned products comply with the provisions listed. This declaration becomes invalid if the product is modified without our agreement. The safety instructions in the operating instructions must be observed.

Bielefeld, 08.07.2024

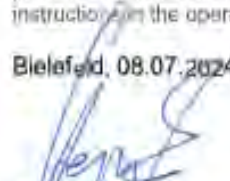

Stephan Krebs
Geschäftsführer

i.A. Frank Thole
Leiter Produktmanagement

Diese Erklärung beinhaltet keine Zusicherung von Eigenschaften.
This declaration does not include any guarantee of product properties.

Reseller

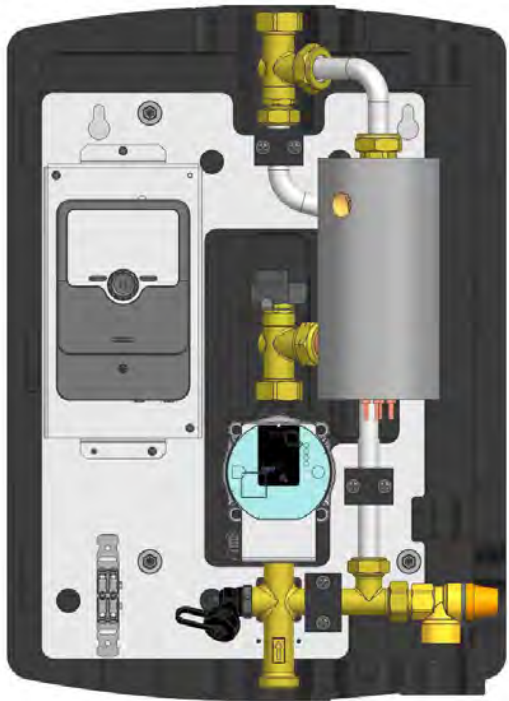



tubra[®] - eTherm P3+

Istruzioni di assemblaggio e d'uso

Indice

- 1 Introduzione..... 3
- 1.1 Scopo d'utilizzo..... 3
- 1.2 Avvertenze di sicurezza..... 3
- 1.3 Documentazione associata..... 5
- 1.4 Fornitura e trasporto 5
- 2 Descrizione funzionale 6
- 2.1 Struttura del sistema nell'installazione..... 6
- 2.2 Descrizione funzionale..... 6
- 3 Struttura – Fornitura 7
- 4 Dati tecnici..... 8
- 4.1 Generale..... 8
- 4.2 Dimensioni / Ingombro..... 8
- 4.3 Perdita di pressione / Curva caratteristica della pompa..... 9
- 4.4 Raccordi 9
- 5 Montaggio..... 10
- 5.1 Montaggio a parete..... 10
- 5.2 Collegamento idraulico serbatoio di accumulo..... 10
- 5.3 Allacciamento elettrico 11
- 5.4 Cascata 13
- 6 Messa in funzione 14
- 6.1 Controllo della tenuta e riempimento dell'impianto 14
- 6.2 Prima messa in funzione 15
- 7 Uso..... 15
- 7.1 Dispositivo di regolazione 15
- 7.2 Valvola di non ritorno 15
- 7.3 Impostazioni..... 15
- 8 Manutenzione / Servizio 16
- 9 Guasti, cause e la loro eliminazione..... 17
- 10 Messa fuori funzione 18



1 Introduzione

Le presenti istruzioni descrivono il montaggio della stazione elettrotermica **tubra®-eTherm P3+** come anche il suo impiego e la sua manutenzione.

La presente guida si rivolge a personale specializzato che dispone delle rispettive nozioni del settore, permettendogli l'esecuzione di lavori che interessano impianti di riscaldamento, condotte d'acqua ed installazioni elettriche. L'installazione e la messa in funzione possono essere effettuate solamente da personale specializzato qualificato.

La stazione può essere montata e azionata solamente in locali asciutti e protetti dal gelo. Leggere attentamente queste istruzioni prima di iniziare i lavori di installazione. La mancata osservanza di queste istruzioni invaliderà tutti i diritti di garanzia.

Le figure sono esemplificative e possono divergere dal prodotto acquistato. Con riserva di modifiche tecniche ed errori.

Non è permesso né duplicare né rendere accessibile a terzi la presente guida di montaggio e d'uso (§ 2 della legge sulla tutela dei diritti d'autore federale - abbreviata UrhG, § 823 del codice civile federale - abbreviato BGB).

1.1 Scopo d'utilizzo

La stazione elettrotermica **tubra®-eTherm P3+** serve esclusivamente al riscaldamento di acqua tramite elemento di riscaldamento elettronico durante il suo flusso. Va riscaldata solamente acqua sanitaria a norma VDI 2035.

1.2 Avvertenze di sicurezza

Oltre alle direttive proprie di ogni paese e alle norme locali, devono essere osservate le seguenti regole tecniche:

- DIN 1988 Regole tecniche per l'installazione di impianti di acqua potabile
- DIN 18 380 Impianti di riscaldamento e impianti centralizzati di riscaldamento dell'acqua
- VDI 2035 Formazione di detriti in impianti di riscaldamento di acqua potabile ed impianti di riscaldamento ad acqua calda
- DIN 4753 Riscaldatori dell'acqua ed impianti di riscaldamento dell'acqua per acqua potabile ed acqua di processo
- DIN EN 60335-1 Sicurezza degli apparecchi elettrici per uso domestico e similare Parte 1: Norme generali
- DIN EN 60335-2 Sicurezza degli apparecchi elettrici per uso domestico e similare Parte 2: Requisiti speciali
- Disposizioni acqua potabile Regolamento riguardante l'acqua potabile
- DVGW (Associazione di settore) W551 Impianti di riscaldamento dell'acqua potabile e della rete idrica
- BGV, ossia Norme antinfortunistiche dell'associazione di categoria professionale
- VDE 0100 Serie di norme Installazione di impianti elettrici
- EN 806-2 Istruzioni tecniche per installazioni riguardanti acqua potabile - Requisiti per elementi costruttivi, apparecchi e materiale costruttivo
- Direttive degli enti fornitori di energia e acqua
- Indicazioni sulla targhetta
- Dati tecnici



Poiché sull'impianto possono verificarsi temperature > 60 °C, sussiste pericolo di scottature ed eventualmente pericolo di ustioni per contatto con i componenti.



Gruppo di riferimento

Le presenti istruzioni per l'uso sono destinate agli utenti dell'impianto di riscaldamento. Questo dispositivo può essere utilizzato da bambini di età pari o superiore a 3 anni e da persone con ridotte capacità fisiche, sensoriali o mentali o con mancanza di esperienza e conoscenza, a condizione che abbiano ricevuto supervisione o istruzioni sull'uso dell'apparecchio in modo sicuro e che comprendano i pericoli connessi.

 Attenzione	<p>Sorvegliare i bambini in prossimità del dispositivo.</p> <ul style="list-style-type: none"> - I bambini non devono giocare con il dispositivo. - La pulizia e la manutenzione da parte dell'utente non devono essere eseguite da bambini senza supervisione.
--------------------------------------------------------------------------------------------------------	-----------------------------------------------------------------------------------------------------------------------------------------------------------------------------------------------------------------------------------------------------------------------------------------

Collegamento del dispositivo

Le presenti istruzioni per l'uso sono destinate agli utenti dell'impianto di riscaldamento.

- Il collegamento e la messa in funzione del dispositivo devono essere eseguiti esclusivamente da personale specializzato autorizzato.
- Rispettare le condizioni di collegamento elettrico specificate.
- Le modifiche all'impianto esistente possono essere effettuate solo da personale specializzato.

 Pericolo	<p>Un intervento non corretto sull'impianto di riscaldamento può causare incidenti mortali.</p> <ul style="list-style-type: none"> - I lavori elettrici possono essere eseguiti solo da elettricisti qualificati.
------------------------------------------------------------------------------------------------------	----------------------------------------------------------------------------------------------------------------------------------------------------------------------------------------------------------------------------------

Lavorare sul dispositivo

- Eseguire le impostazioni e gli interventi sul dispositivo solo in conformità alle indicazioni contenute nelle presenti istruzioni per l'uso. Ulteriori interventi sull'apparecchio possono essere eseguiti solo da personale specializzato autorizzato.
- Non aprire il dispositivo.
- Non rimuovere l'involucro.
- Non modificare o rimuovere gli accessori installati.
- Non aprire o stringere le connessioni dei tubi.

 Pericolo	<p>Le superfici e i liquidi caldi possono provocare ustioni o scottature.</p> <ul style="list-style-type: none"> - Non aprire il dispositivo. - Non toccare le superfici calde di tubi e raccordi non isolati.
------------------------------------------------------------------------------------------------------	----------------------------------------------------------------------------------------------------------------------------------------------------------------------------------------------------------------------------------------

Danni al dispositivo

 Pericolo	<p>Gli apparecchi danneggiati mettono a rischio la vostra sicurezza.</p> <ul style="list-style-type: none"> - Controllare che l'apparecchio non presenti danni esterni. - Non mettere in funzione un apparecchio danneggiato.
--------------------------------------------------------------------------------------------------------	-------------------------------------------------------------------------------------------------------------------------------------------------------------------------------------------------------------------------------------------------------

Perdita d'acqua dal dispositivo

 Pericolo	<p>Se l'acqua fuoriesce dal dispositivo c'è il rischio di scosse elettriche.</p> <ul style="list-style-type: none"> - Spegnere l'impianto di riscaldamento dall'esterno (ad es. scatola dei fusibili, distribuzione elettrica domestica). - Avvisare un'azienda specializzata in riscaldamento.
--------------------------------------------------------------------------------------------------------	-------------------------------------------------------------------------------------------------------------------------------------------------------------------------------------------------------------------------------------------------------------------------------------------------------------------------

 Pericolo	<p>Se l'acqua fuoriesce dal dispositivo, c'è il rischio di scottature.</p> <ul style="list-style-type: none"> - Non toccare l'acqua calda di riscaldamento.
--------------------------------------------------------------------------------------------------------	----------------------------------------------------------------------------------------------------------------------------------------------------------------------------

Comportamento in caso di guasti all'impianto di riscaldamento

 Pericolo	<p>I messaggi di guasto indicano difetti nell'impianto di riscaldamento. I guasti non eliminati possono avere conseguenze letali.</p> <ul style="list-style-type: none"> - Non riconoscere i messaggi di guasto più volte a brevi intervalli. - Avvisare una ditta specializzata affinché analizzi la causa ed elimini il guasto.
-----------------------------------------------------------------------------------------------	-----------------------------------------------------------------------------------------------------------------------------------------------------------------------------------------------------------------------------------------------------------------------------------------------------------------------------------------------------------

Requisiti del sito di installazione

 Pericolo	<p>Non apportare modifiche successive alle condizioni strutturali che potrebbero influire sulla sicurezza di funzionamento (ad es. passaggio dei cavi, rivestimenti o pareti divisorie).</p>
-----------------------------------------------------------------------------------------------	----------------------------------------------------------------------------------------------------------------------------------------------------------------------------------------------

 Pericolo	<p>Liquidi e materiali altamente infiammabili (ad esempio benzina, solventi e detersivi, vernici o carta) possono provocare deflagrazioni e incendi. Non conservare o utilizzare tali sostanze nel locale caldaia o nelle immediate vicinanze dell'impianto di riscaldamento.</p>
-----------------------------------------------------------------------------------------------	-----------------------------------------------------------------------------------------------------------------------------------------------------------------------------------------------------------------------------------------------------------------------------------

 Attenzione	<p>Le condizioni ambientali non consentite possono danneggiare l'impianto di riscaldamento e comprometterne la sicurezza di funzionamento.</p> <ul style="list-style-type: none"> - Assicurare una temperatura ambiente compresa tra 0 °C e 35 °C. - Evitare l'inquinamento dell'aria dovuto agli idrocarburi alogenati (ad esempio contenuti nelle vernici, nei solventi e nei detersivi) e l'accumulo di polveri pesanti (ad esempio dovute a lavori di carteggiatura). - Evitare un'umidità costantemente elevata (ad esempio a causa dell'asciugatura permanente della biancheria).
-------------------------------------------------------------------------------------------------	--------------------------------------------------------------------------------------------------------------------------------------------------------------------------------------------------------------------------------------------------------------------------------------------------------------------------------------------------------------------------------------------------------------------------------------------------------------------------------------------------------------------------------------------------------------------------------------------------------------------------

Componenti aggiuntivi, parti di ricambio e di usura

 Pericolo	<p>I componenti che non sono stati testati con l'impianto di riscaldamento possono causare danni all'impianto di riscaldamento o comprometterne le funzioni. L'installazione o la sostituzione deve essere effettuata solo da una ditta specializzata.</p>
-------------------------------------------------------------------------------------------------	------------------------------------------------------------------------------------------------------------------------------------------------------------------------------------------------------------------------------------------------------------

1.3 Documentazione associata

Osservare anche le istruzioni per l'installazione e il funzionamento dei componenti utilizzati, ad esempio l'unità di controllo.

1.4 Fornitura e trasporto

Verificare la completezza e l'integrità della merce immediatamente dopo il ricevimento. Comunicare immediatamente eventuali danni o reclami.



2 Descrizione funzionale

2.1 Struttura del sistema nell'installazione

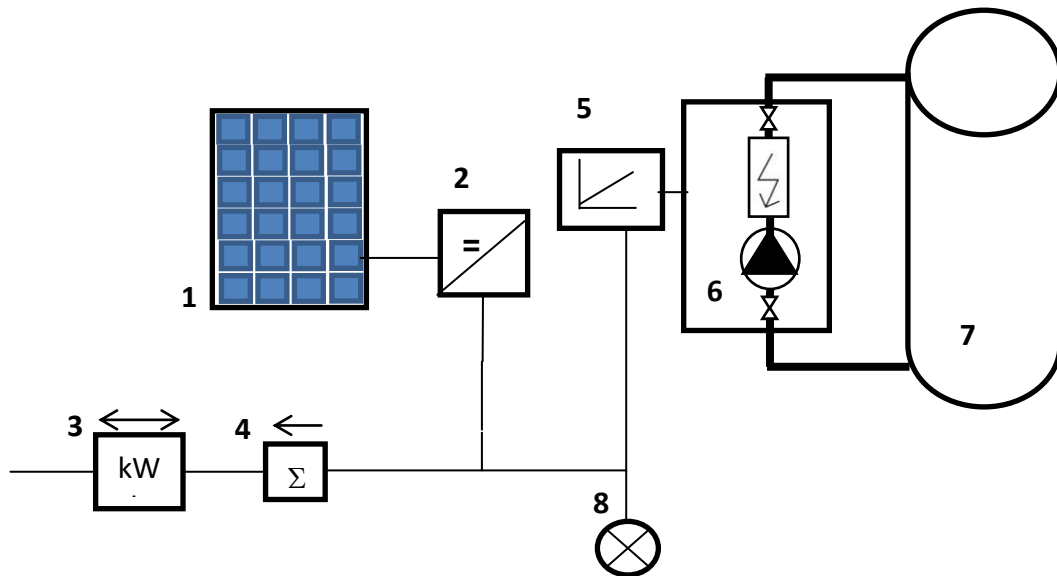

- 1 Impianto fotovoltaico
- 2 Invertitore
- 3 Contatore elettrico (fonte, alimentazione)
- 4 tubra[®]-eTherm P3+ sensor (rilevamento prestazione alimentazione)
- 5 tubra[®]-eTherm P3+ power (modulazione della prestazione)
- 6 tubra[®]-eTherm P3+ mit tubra[®]-eTherm controller P
- 7 Bollitore termico
- 8 Consumatore casalingo (luce, standby, ...)

2.2 Descrizione funzionale

Il **tubra[®]-eTherm P3+** è una stazione elettrotermica che converte l'elettricità fotovoltaica in calore e lo accumula in serbatoi tampone.

Grazie alla regolazione continua della potenza del **tubra[®]-eTherm P3+**, l'elettricità in eccesso può essere utilizzata in modo ottimale. La pompa di carica a velocità controllata carica il bollitore a un livello di temperatura immediatamente utilizzabile. Quando viene raggiunta la temperatura massima della bombola, la carica viene interrotta.

I vantaggi sono:

- Adattamento ottimale grazie alla potenza modulante a variazione continua fino a 3000 W
- Caricamento stratificato del bollitore, anche in caso di montaggio successivo su bollitori esistenti
- Temperatura nominale regolabile
- Calore immediatamente utilizzabile anche in caso di basso irraggiamento solare
- Può essere installato in un secondo momento su qualsiasi bollitore
- Indipendente dall'inverter fotovoltaico, dall'energy manager e dal contatore

L'unità di controllo è costituita dal regolatore con elettronica di potenza (5) e dall'unità di misura (4). L'unità di misura fornisce misura il flusso di corrente direttamente a monte del contatore di elettricità (3). Se viene rilevata una potenza sufficientemente elevata, questa corrente fotovoltaica può essere utilizzata per il riscaldamento elettrico dell'acqua.

Il regolatore utilizza l'unità di potenza per regolare i livelli di potenza nella stazione elettrotermica per il riscaldamento del bollitore. Grazie al principio dello scaldacqua istantaneo con controllo della velocità della pompa, il **tubra[®]-eTherm P3+** fornisce calore a un livello di temperatura elevato al bollitore anche con una bassa potenza termica, ad esempio nelle giornate nuvolose. Ciò consente di caricare il bollitore a strati.

3 Struttura – Fornitura

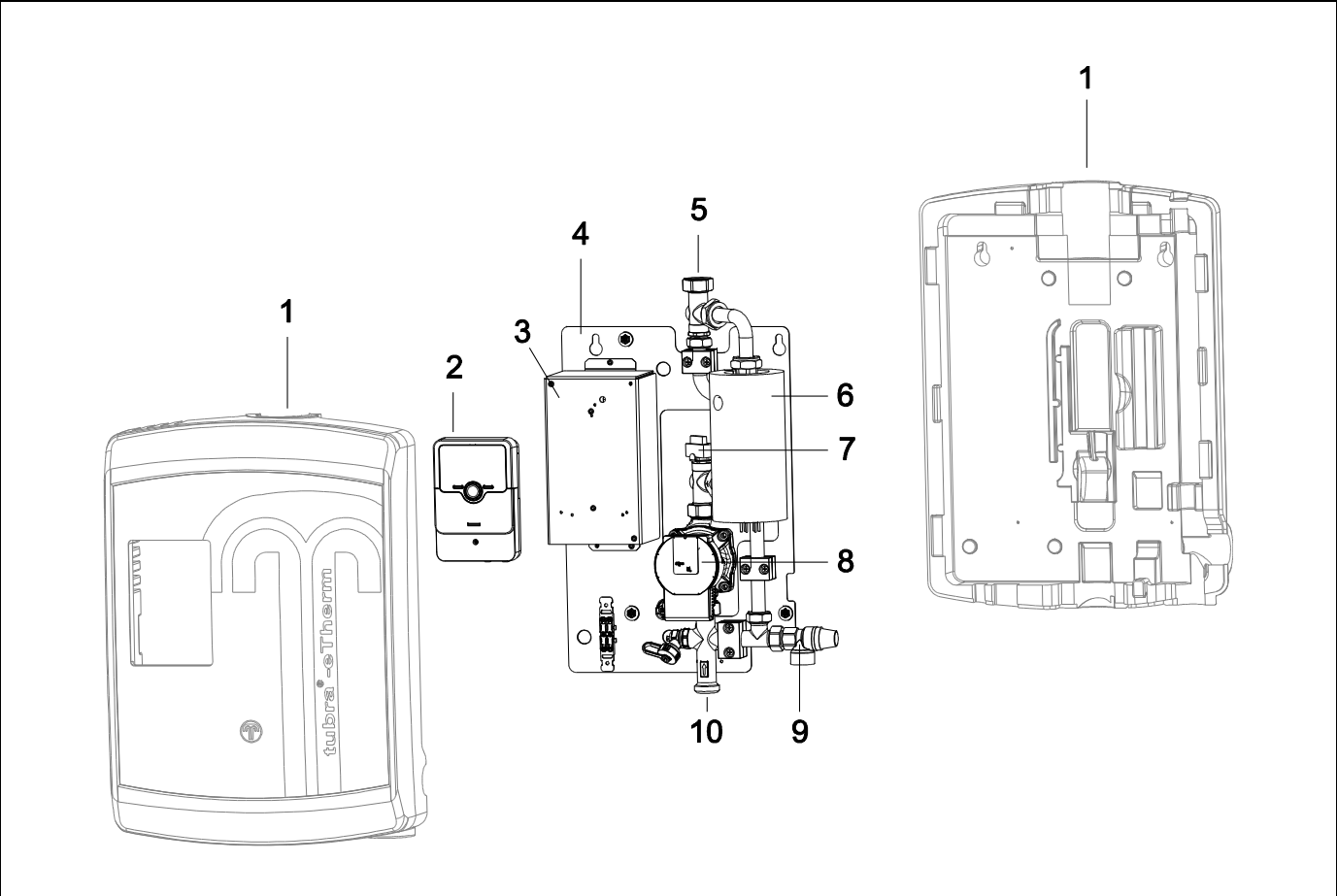

Pos.	Denominazione
1	Guscio isolante
2	Regolamento
3	Scatola di collegamento per STB e contattori
4	Piastra
5	Rubinetto a sfera Mandata
6	Termoelemento + guscio isolante
7	Sensore di pressione
8	Pompa
9	Elemento a croce con valvola di sicurezza a 3 bar e valvola di non ritorno
10	Rubinetto a sfera Ritorno



4 Dati tecnici

4.1 Generale

Descrizione / Tipo	tubra®-eTherm P3+
Corrente e potenza nominale	0 – 3 kW (13 A)
Collegamento elettrico	1/PE 230 V AC 50 – 60 Hz
Richiesto Sezione trasversale condotto	2,5 mm ²
Contenuto nominale	0,2 l
Termoelemento	0,8 kW / 0,8 kW / 1,4 kW
Flusso	2 l/h – 300 l/h
Caduta di pressione	0,6 bar a 300 l/h
Intervallo termico regolabile	30 °C – 80 °C
Collegamento dell'acqua	Rp 3/4" IG
Peso (pieno d'acqua)	14 kg
Tipo di protezione eTherm power	IP 22

Descrizione / Tipo		tubra®-eTherm P3+ 951.15.00.00
Modello		Acqua sanitaria
Potenza nominale		0 - 3 kW
Max. pressione di esercizio		3 bar
Max. temperatura di esercizio		95 °C
Pompa di circolazione		Wilo Para ST 15/7 iPWM2 Potenza assorbita: 3-45 W
Materiali	Alloggiamento/ Raccordi di collegamento	CW617N (2.0402)
	Termoelemento	Rame
	Guarnizioni	EPDM
	Isolamento	Schiuma EPP 0,038 W/mK

4.2 Dimensioni / Ingombro

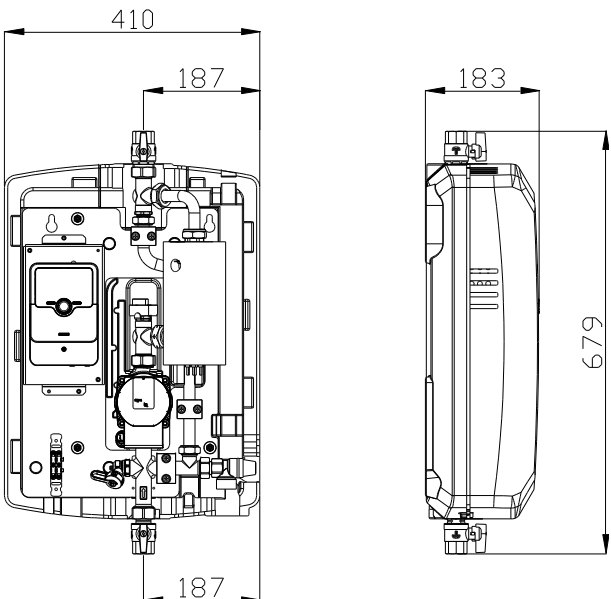
	<p>Dimensioni ed ingombro minimo Lavori di montaggio e manutenzione</p>
-------------------------------------------------------------------------------------	-----------------------------------------------------------------------------

4.3 Perdita di pressione / Curva caratteristica della pompa

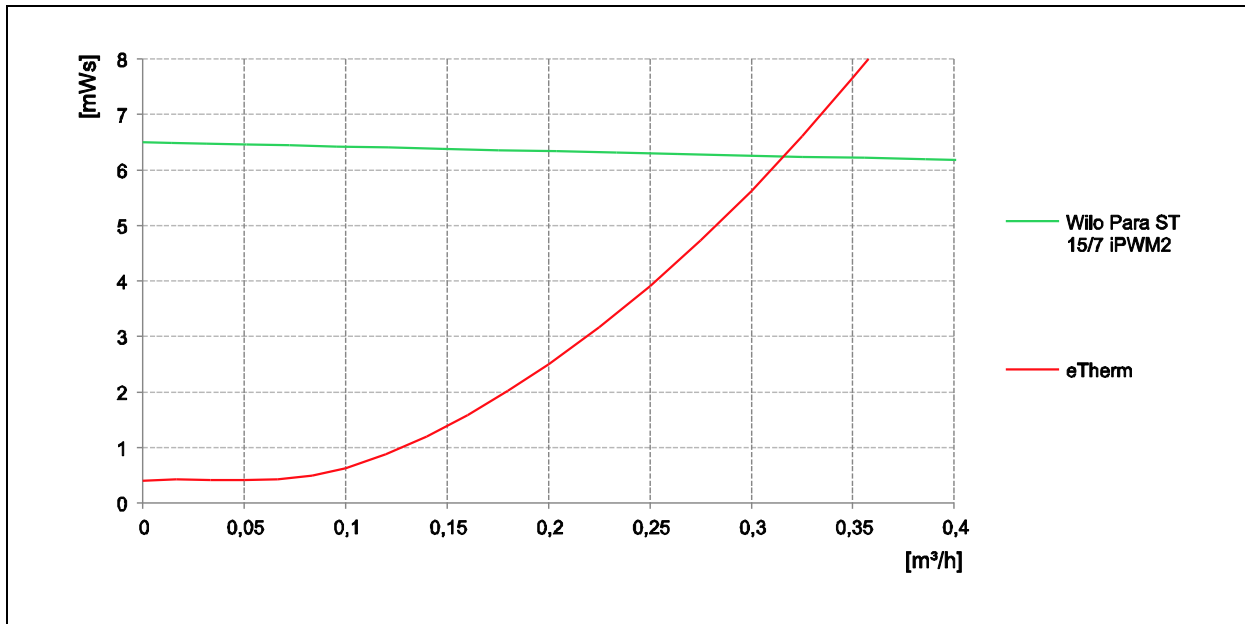

4.4 Raccordi

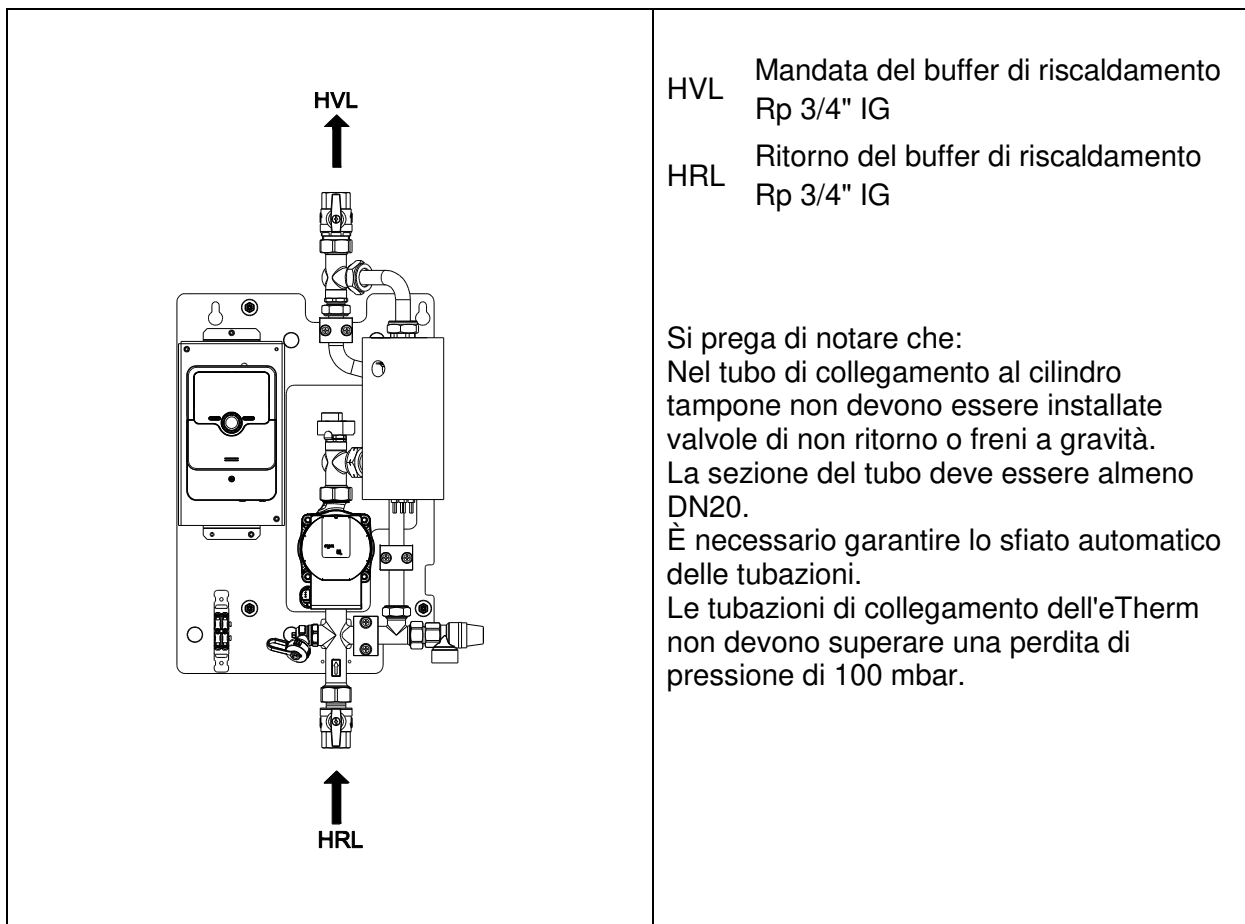

5 Montaggio

5.1 Montaggio a parete

	<p>Contrassegnare ed eseguire 2 fori da \varnothing 10mm secondo il disegno a lato ed inserire dei tasselli ad espansione. Avvitare la vite superiore con la rondella fino a che la testa della vite si trova ad una distanza di 1 cm dalla parete. Agganciare la stazione, allinearla con una livella a bolla e fissarla con la seconda vite e rondella.</p> <p>Serrare entrambe le viti in maniera uniforme.</p>
--	---------------------------------------------------------------------------------------------------------------------------------------------------------------------------------------------------------------------------------------------------------------------------------------------------------------------------------------------------------------------------------------------------------------------------------

5.2 Collegamento idraulico serbatoio di accumulo

<p>tubra®-eTherm P3+ con serbatoio acqua potabile</p>	<p>tubra®-eTherm P3+ con serbatoio di accumulo</p>
<p>Illustrazione esemplificativa, non ha alcuna pretesa di completezza e non sostituisce la progettazione a regola d'arte.</p>	
<p>Denominazione</p>	<p>Descrizione</p>
<p>VL</p>	<p>Mandata</p>
<p>RL</p>	<p>Ritorno</p>

5.3 Allacciamento elettrico

5.3.1 Generale

I lavori sull'impianto elettrico e l'apertura delle custodie dei componenti elettrici possono essere effettuati solamente a corrente elettrica scollegata e solo da personale specializzato opportunamente autorizzato. Negli attacchi verificare la corretta polarità e il corretto collegamento dei morsetti. Proteggere il dispositivo di regolazione e i componenti elettrici dalla sovratensione.

 <p>Pericolo!</p>	<p>In caso di un collegamento elettrico non a regola d'arte sussiste pericolo di vita a causa di una scossa elettrica.</p> <ul style="list-style-type: none"> → Eseguire il collegamento elettrico solo attraverso un perito elettrico autorizzato dal fornitore di energia locale e attenendosi alle norme vigenti "in loco". → Prima di eseguire dei lavori, disconnettere dalla fonte di alimentazione elettrica.
-----------------------------------------------------------------------------------------------------------	----------------------------------------------------------------------------------------------------------------------------------------------------------------------------------------------------------------------------------------------------------------------------------------------------------------------------------------------------------------------------------------------------------------------------------------------

La stazione è completamente preassemblata e precablata in fabbrica. Per la messa in funzione, è necessario collegare il cavo di rete e stabilire il collegamento bus con l'unità di controllo.

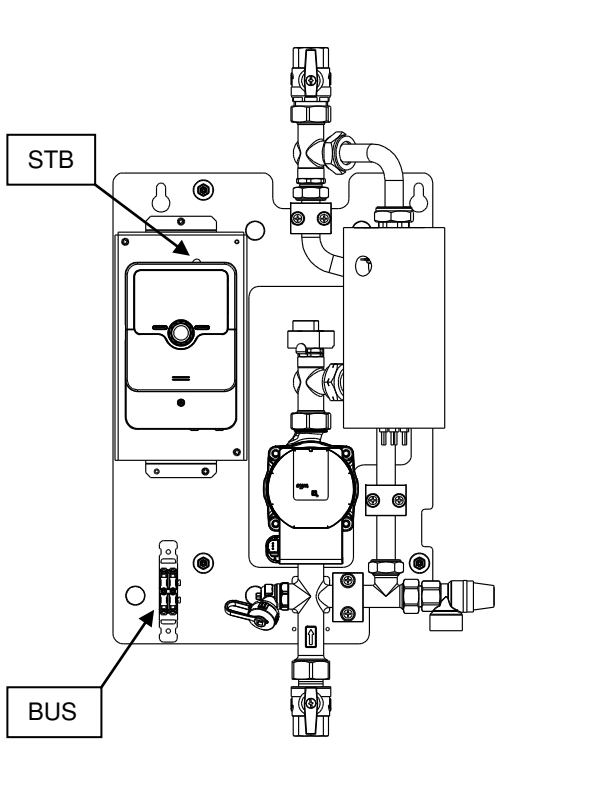
	<p>Il connettore alla rete deve essere connesso in modo fisso ad un fusibile proprio (16A) tramite condotto separato di 2,5 mm².</p> <p>A tal fine, cablare la spina in dotazione e inserirla nella presa collegata alla stazione.</p> <p>STB – Resettare qui il riduttore di sicurezza della temperatura dopo che è stato attivato.</p> <p>Il collegamento BUS è protetto contro l'inversione di polarità.</p>
------------------------------------------------------------------------------------	----------------------------------------------------------------------------------------------------------------------------------------------------------------------------------------------------------------------------------------------------------------------------------------------------------------------------------------------------------------------------------------------------------------------------

Ulteriori dettagli sono riportati nel relativo manuale del dispositivo di regolazione.

Assegnazione dei sensori

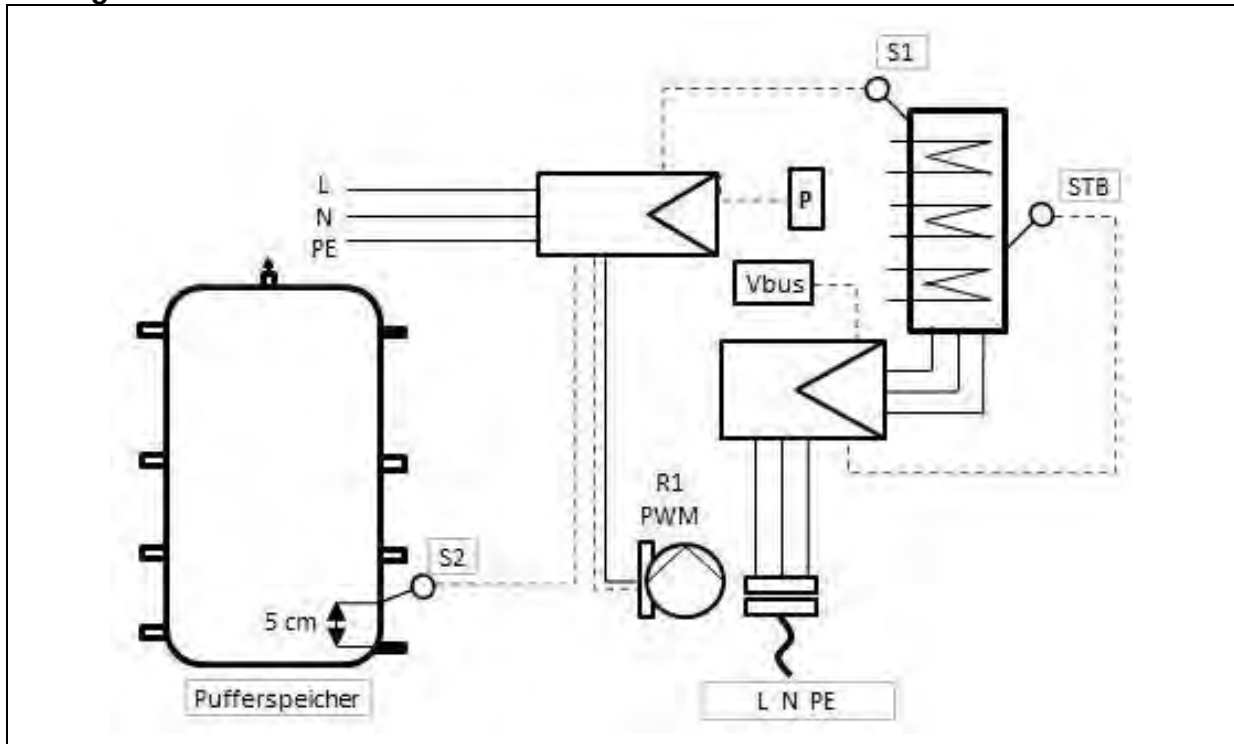

- S1 Sensore di temperatura eTherm
- S2 Sensore di temperatura del fondo del bollitore
- STB Sensore di temperatura Limitatore di temperatura di sicurezza
- R1 Pompa
- Vbus Linea di comunicazione con il modulo sensore

Posizione del sensore Fondo del bollitore Sensore S2:

- 5 cm sopra il collegamento di ritorno dell'eTherm P+

○

- Nel manicotto d'immersione più basso del bollitore

Installare il sensore **tubra®-eTherm P3+** nell'armadio di collegamento dell'abitazione, di fronte al contatore d'immissione, e collegarlo al controller **tubra®-eTherm P3+** tramite V-BUS.

5.4 Cascata

5.4.1 Collegamento idraulico

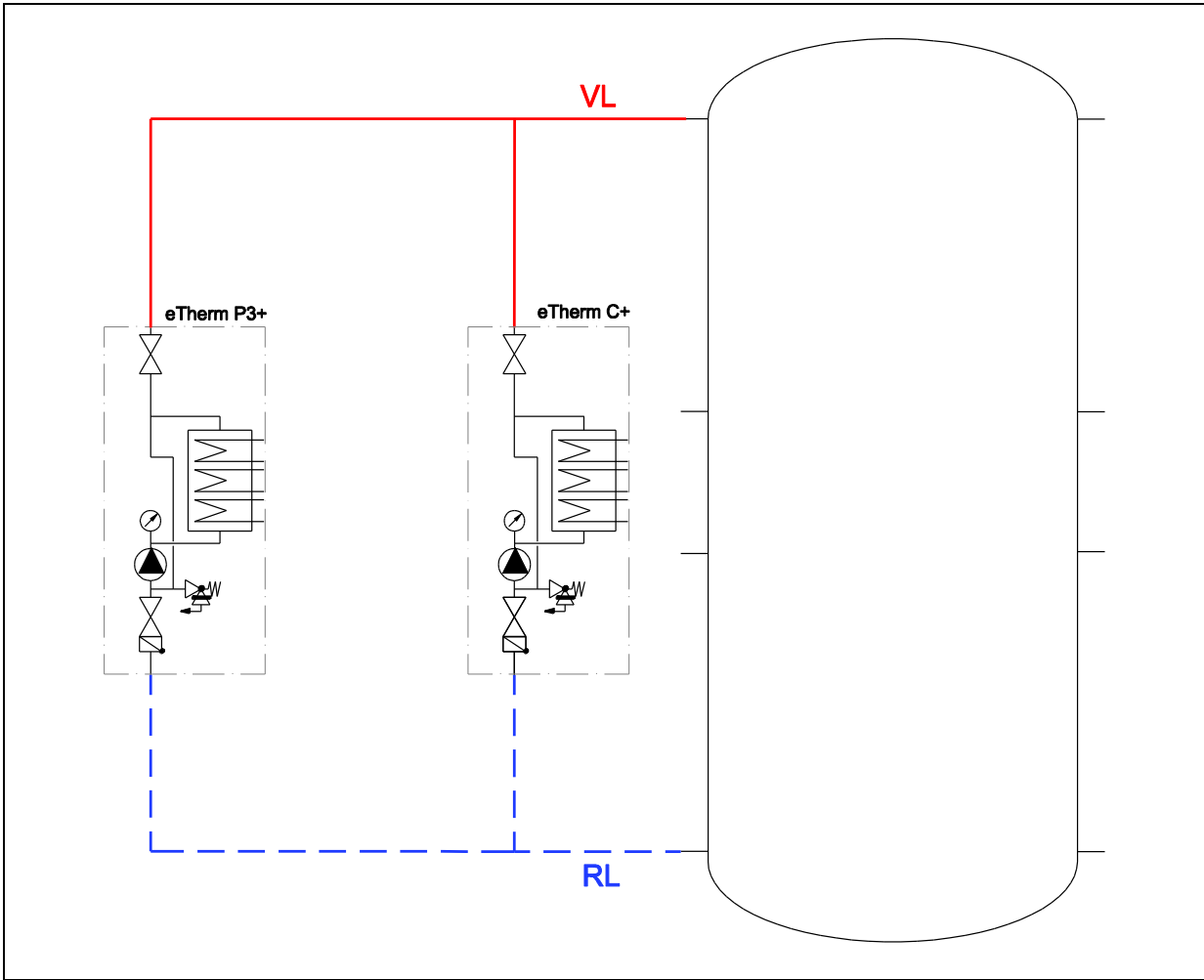

	eTherm P3+	eTherm C+		
		Relè R3	Relè R2	
		Termoelemento C3	Termoelemento C2	Termoelemento C1
0-3 kW	x			
0-6 kW	x	x		
0-9 kW	x	x	x	
0-12 kW	x	x	x	x

Come cascata **tubra®-eTherm P3+** in cascata **e tubra®-eTherm C+**, fino a 12.000 W di potenza termica possono essere implementati nei gruppi idraulici.

Funzione di selettore di utenze esterne: Relè R3 con 3 kW
 Funzione di selettore di utenze esterne 2: Rele R2 con 3 kW o 6 kW

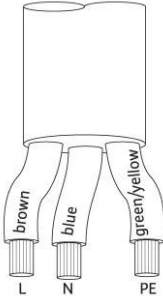
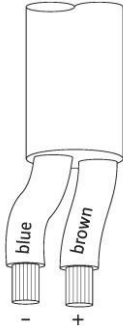

5.4.2 Pompa di circolazione

Allacciamento elettrico pompa 	Collegamento PWM 
L = marrone N = blu PE = verde/giallo	+ = marrone - = blu

6 Messa in funzione

Sarà possibile mettere in funzione l'impianto solamente se tutti i componenti idraulici ed elettrici sono stati completamente installati.

6.1 Controllo della tenuta e riempimento dell'impianto

Verificare la tenuta di tutti i componenti dell'impianto inclusi tutti gli elementi e le stazioni prefabbricati in stabilimento e in caso di mancanze di tenuta sigillare opportunamente. Durante questa operazione adattare la pressione di prova e la durata della prova al relativo sistema di tubazioni e alla relativa pressione di esercizio.

Riempire il sistema di riscaldamento esclusivamente con acqua filtrata ed eventualmente trattata secondo la norma VDI 2035 e sfiatare completamente l'impianto.

6.2 Prima messa in funzione

Rispettare al proposito le relative istruzioni del dispositivo.



Pericolo!

Il sistema va prima della prima messa in funzione elettrica riempito con acqua e spurgato.

Fase di lavoro	Procedura	OK
Preparazione e controllo	<ul style="list-style-type: none"> Controllo visivo dell'installazione Tutti i sensori sono stati installati e collegati correttamente? Tutte le uscite sono state collegate? 	<input type="checkbox"/> <input type="checkbox"/> <input type="checkbox"/>
Attivare il dispositivo di regolazione	Mettere sotto tensione il dispositivo di regolazione.	<input type="checkbox"/>
Impostazione del dispositivo di regolazione	Rispettare le istruzioni del dispositivo di regolazione. <ul style="list-style-type: none"> Selezionare temperatura obiettivo Selezionare temperatura max accumulatore Avviare procedura di messa in funzione standardizzata 	_____ - _____ _____

7 Uso

7.1 Dispositivo di regolazione

Rispettare al proposito le istruzioni di montaggio e d'uso del dispositivo di regolazione impiegato.

7.2 Valvola di non ritorno

Al fine di evitare una circolazione errata, vi è integrato una valvola di non ritorno sopra la pompa nel circuito di ritorno.

7.3 Impostazioni

Impostare temperatura obiettivo e temperatura max accumulatore.

Rispettare al proposito le istruzioni di montaggio e d'uso del dispositivo di regolazione impiegato.



8 Manutenzione / Servizio

Il produttore raccomanda la manutenzione sotto forma di una funzione e un controllo visivo da parte del personale autorizzato e specializzato. A seconda della qualità dell'acqua e dell'età del sistema, l'intervallo di manutenzione deve essere compreso tra 1 e 3 anni.

In questo contesto vanno controllate le impostazioni secondo il protocollo di messa in funzione.

Nella modalità di funzionamento manuale **tubra®-eTherm P3+** va impiegata con diverse prestazioni di riscaldamento e controllato l'esatto funzionamento.

Componenti	Controllo
Termoelemento elettronico	Con prestazione termica massima, il riscaldamento dovrebbe avvenire senza avvertire ebollizione, in caso contrario pulire ed eventualmente decalcificare i termoelementi elettronici.



9 Guasti, cause e la loro eliminazione

Gli eventuali messaggi di errore vengono visualizzati sul display del dispositivo di regolazione. Rispettare al proposito le relative istruzioni del dispositivo.

Guasto	Possibile causa	Correzione
Troppo basso il flusso volumetrico (Δt troppo alto)	Elemento riscaldante elettrico sporco / calcificato	Pulire, decalcificare o sostituire se necessario
	Pompa difettosa	Sostituire la pompa
	Logica di controllo della pompa non funzionante	Controllare la posizione e il funzionamento dei sensori, se necessario sostituirli
Temperatura obiettivo non raggiunta	Temperatura target non raggiunta	Controllare i sensori, se necessario sostituirli
Nessun riscaldamento dell'elemento riscaldante	Raggiunta la temperatura massima del bollitore	Monitorare il sistema, attendere il riavvio
	Sensore di pressione attivato	Aumentare la pressione di esercizio a > 1,2 bar
	STB attivato	Ripristino
	Fühler S1 difettoso → Sostituire il sensore S1	Se l'STB viene attivato, la causa deve essere determinata da un tecnico specializzato. È quindi necessaria una messa in funzione completa con verifica di tutte le funzioni.
	Elemento riscaldante difettoso	Controllare l'elemento riscaldante, se necessario sostituirlo
Rumori di ebollizione dall'elemento riscaldante	Nessun riscaldamento dell'elemento riscaldante → il fusibile è scattato	Controllare l'impianto elettrico, riattivare il fusibile.
	Asta di riscaldamento calcificata	Decalcificazione dell'elemento riscaldante
	Aria nel sistema	Installare lo sfiato automatico dell'aria
Rumori di ebollizione dall'elemento riscaldante	Perdita di pressione nel bollitore troppo elevata	Eliminare i raccordi non necessari o aumentare le dimensioni delle tubazioni

LED	Significato	Stato di funzionamento	Causa	Eliminazione
lampeggia in verde	Pompa in funzione	La pompa gira secondo le impostazioni fatte	Funzionamento normale	
lampeggia in verde velocemente	Versione PWM	Pompa in stand-by	Funzionamento normale	
lampeggia verde/rosso	La pompa è pronta all'impiego, ma non gira	La pompa inizia autonomamente a girare non appena l'errore non sussiste più	1. Sottotensione U < 160 V	1. Verificare alimentazione di tensione 195 V < U < 253 V
			2. Sovratensione U > 253 V	
lampeggia in rosso	Pompa guasta	Pompa bloccata	2. Modulo-sovratemperatura: temperatura motore troppo alta	2. Controllare temperatura die liquidi e dell'ambiente circostante
			La pompa non si aziona nuovamente in modo autonomo	Sostituire la pompa
LED spento	Nessuna alimentazione di tensione	Sistema elettronico privo di tensione	1. Collegamento tra regolatore e pompa interrotto	1. Verificare collegamento cavi
			2. LED è guasto	2. Verificare se la pompa gira
			3. Sistema elettronico guasto	3. Sostituire pompa

Se non è possibile eliminare il malfunzionamento, rivolgersi al rivenditore autorizzato o al servizio clienti Wilo.



10 Messa fuori funzione

Temporanea

Se la stazione elettrotermica **tubra[®]-eTherm P3+** rimane fuori servizio per lungo tempo in un locale a rischio di gelo, sarà necessario interrompere l'alimentazione di corrente e svuotare completamente l'impianto. A tal fine allentare l'avvitamento in basso del termoelemento e l'avvitamento della pompa in basso per svuotarla completamente.

Definitiva

Se la stazione solare **tubra[®]-eTherm P3+** viene messa definitivamente fuori servizio, interrompere l'alimentazione di corrente a tutte le parti interessate dell'impianto e svuotare completamente tutte le tubazioni interessate e tutte le parti dell'impianto. A tal fine allentare l'avvitamento in basso del termoelemento e l'avvitamento della pompa in basso per svuotarla completamente.

La messa fuori servizio definitiva, lo smontaggio e lo smaltimento devono essere effettuati solamente da personale specializzato opportunamente qualificato. I componenti e i materiali devono essere opportunamente smaltiti in conformità alle norme vigenti.





Konformitätserklärung Declaration of Conformity



Hersteller:
Manufacturer:
D – 33659 Bielefeld

Gebr. Tuxhorn GmbH & Co.KG
Senner Straße 171

Produktbezeichnung:
Product description:

tubra®-eTherm P3+/P9+
(controller / power / sensor)
tubra®-eTherm C3+/C9+; tubra®-eTherm S3/S9

EU-Richtlinien:
EC-Directives:

Directive 2014/30/EU - EMC
Directive 2014/35/EU
Directive 2009/125/EC
Directive 2011/65/EU

electromagnetic compatibility
electrical equipment designed for use within certain voltage limits
ecodesign requirements for energy-related products
certain hazardous substances in electrical and electronic equipment RoHS

Angewendete Normen:
Standards:

Pumpe / Regler / Heizelement

DIN EN 16297-1/3:2013-04

Pumps - Rotodynamic pumps - Glandless circulators - Part 1/3

EN 55014-1:2021

Electromagnetic compatibility - Part 1

EN 55014-2:2021

Electromagnetic compatibility - Part 2

EN 60335-1:2024; VDE 0700-1:2024

Household and similar electrical appliances

+AC:2014+A11:2014+A13:2017+A1:2019
+A2:2019+A14:2019+A15:2021+A16:2023

DIN EN 60335-2-35 VDE 0700-35:2022-10 + A1:2019 + A2:2021

Sicherheit elektrischer Geräte für den Hausgebrauch und ähnliche Zwecke, Besondere Anforderungen für Durchflusserwärmer

DIN EN 60730-1 VDE 0631-1:2021-06

Automatic electrical controls

DIN EN IEC 60730-2-9

Automatic electrical controls - Part 2-9

VDE 0631-2-9:2021-01

EN ICE 61000-6-3:2021

Electromagnetic compatibility (EMC) - Part 6-3

EN ICE 61000-6-4:2019

Electromagnetic compatibility (EMV) - Teil 6-4

EN IEC 61000-6-1/2:2019

Electromagnetic compatibility (EMC) - Part 6-1 / Part 6-2

DIN EN ISO 9001:2015-11

Quality management systems - Requirements (ISO 9001:2015)

DIN EN IEC 63000:2019-05

Assessment of electronic products with respect to the restriction of hazardous substances

VDE 0042-12:2019-05

Wir, die Gebr. Tuxhorn GmbH & Co.KG, erklären hiermit, dass die oben genannten Produkte den aufgeführten Bestimmungen entsprechen. Bei einer nicht mit uns abgestimmten Änderung des Produktes verliert diese Erklärung ihre Gültigkeit. Die Sicherheitshinweise in der Betriebs- und Bedienungsanleitung sind zu beachten.

We, Gebr. Tuxhorn GmbH & Co. KG, hereby declare that the above-mentioned products comply with the provisions listed. This declaration becomes invalid if the product is modified without our agreement. The safety instructions in the operating instructions must be observed.

Bielefeld, 08.07.2024

Stephen Krebs
Geschäftsführer

i.A. Frank Thole
Leiter Produktmanagement

Diese Erklärung beinhaltet keine Zusicherung von Eigenschaften.
This declaration does not include any guarantee of product properties.



Rivenditore

